



**INSTALLATION**  
**OPERATION**  
**AND**  
**MAINTENANCE**  
**OF THE**  
**FONT'N-AIRE "READY" FLOATING FOUNTAINS**

This manual is designed to aid in the installation; operation and maintenance of Font'N-Aire "Ready" floating fountain. **Do not dispose of this manual!** Provide this manual to the owner.

The following information is provided to alert persons to potential personal injury hazards inherent with products.

**! DANGER:** Indicates an eminently hazardous situation which, if not avoided, will result in death or serious injury.

**! WARNING:** Indicates a potentially hazardous situation which, if not avoided, could result in death or serious injury.

**! CAUTION:** Indicates a potentially hazardous situation which may result in minor or moderate injury.

January 1, 2008



## SAFETY DATA INFORMATION SHEET

- ! DANGER:** RISK OF ELECTRIC SHOCK. DO NOT INSTALL THIS EQUIPMENT IN SWIMMING AREAS. THIS EQUIPMENT HAS NOT BEEN INVESTIGATED FOR USE IN SWIMMING AREAS.
- ! WARNING:** DISCONNECT AND LOCK OUT ELECTRICAL POWER BEFORE ANY SERVICE IS PERFORMED ON THIS DEVICE.
- ! WARNING:** THE CONTROL PANEL AND UNIT MUST BE GROUNDED. FAILURE TO CONNECT TO A PROPER GROUND COULD RESULT IN PERSONAL INJURY OR DEATH.
- ! WARNING:** BEFORE ATTEMPTING TO INSTALL, SERVICE OR MAINTAIN THE UNIT AND/OR FLOTATION IN ANY BODY OF WATER A COAST GUARD APPROVED PERSONAL FLOTATION DEVICE (PFD; TYPE III OR HIGHER) MUST BE WORN.
- ! WARNING:** THE FLOTATION PROVIDED FOR THIS EQUIPMENT, HAS NOT BEEN INVESTIGATED PERSONAL FLOTATION DEVICE.
- ! WARNING:** ATTEMPTING TO INSTALL OR SERVICE EQUIPMENT FROM AN UNSTABLE WORK PLATFORM COULD RESULT IN DEATH OR INJURY.
- ! WARNING:** POSSIBLE CUTTING HAZARD. ROTATING PROPELLER COULD RESULT IN SERIOUS INJURY. TURN OFF POWER AND LOCK OUT BEFORE INSTALLATION OR SERVICING.
- ! NOTICE:** DO NOT OPERATE THIS EQUIPMENT OUT OF THE WATER.
- (EXCEPTION:) IT IS PERMISSABLE TO BUMP RUN 3-PHASE EQUIPMENT OUT OF THE WATER TO VERIFY COUNTER CLOCKWISE MOTOR ROTATION WITH A RAPID ON/OFF OPERATION.
- ! CAUTION:** INSTALLATION OR SERVICE WORK MUST BE PERFORMED FROM A STABLE WORK PLATFORM TO AVOID THE POSSIBILITY OF CAPSIZING.



## FONT'N-AIRE "READY"

### ASSEMBLY AND INSTALLATION INSTRUCTIONS

**! WARNING:** DO NOT INSTALL OR USE THIS DEVICE IN SWIMMING AREAS

- STEP 1 Remove the Font'N-Aire Ready unit from the shipping carton. ***Do not dispose of the shipping container and packing in the unlikely event of return for service. SAVE THE PACKAGING!***
- STEP 2 Remove the flotation from the shipping carton. (If a light kit was purchased with the unit, see the enclosed light kit instructions at this time.)

### INSTALLATION & MOORING OF FLOAT

**!WARNING:** DO NOT USE AS A PERSONAL FLOTATION DEVICE.

- STEP 1 To anchor: Cut 2 lengths of 1/4" polyethylene rope, allowing for 2 to 3 feet of rope for every foot of water depth. Most commonly the unit is anchored by two 8" x 8" x 16" concrete building blocks (one per corner diagonally). See the enclosed suggested mooring drawing. This type of anchor allows the anchor to bury itself in the mud or lake bottom.
- STEP 2 Insert one rope end into one of the mooring holes in the float and tie off. Do the same on the opposite diagonal corner. Only two opposing corners are needed for secure mooring.
- STEP 3 The mooring ropes, as an alternative, may be tied off to the shore. Be certain to allow for variations in water level when determining shore mooring rope length.
- STEP 4 Place the Ready fountain into the flotation. No mounting hardware is needed or required.



## ELECTRICAL

### ALL ELECTRICAL CONNECTIONS SHALL BE WIRED PER N.E.C., C.E.C., OR LOCAL ELECTRIC CODES

**! DANGER:** RISK OF ELECTRICAL SHOCK. DO NOT INSTALL OR USE THIS DEVICE IN SWIMMING AREAS. THIS PUMP HAS NOT BEEN INVESTIGATED FOR USE IN SWIMMING AREAS.

**! DANGER:** ROTATING PROPELLER COULD RESULT IN SERIOUS INJURY. TURN OFF POWER BEFORE SERVICING MACHINE.

**! WARNING:** RISK OF ELECTRIC SHOCK. CONNECT ONLY TO A PROPERLY GROUNDED CONNECTION. FAILURE TO CONNECT TO PROPER GROUND COULD RESULT IN PERSONAL INJURY.

### E.L.C.I. INFORMATION

An Equipment Leakage Current Interrupter is provided on FONT'N-AIRE READY equipment manufactured for use in the United States. Canadian Electric Codes require protection at the service entrance.

The ELCI used on USA Font'N-Aire Ready 230-volt equipment is rated for 20amps and has a nominal trip level of 30 mA. The E. L.C.I. is used as **an Equipment Leakage Circuit Interrupter** device **only**. The E.L.C.I. is **not** a circuit breaker nor should it be used as an on/of switch. .

Selecting the correct gauge and length of power supply wire is mandatory to avoid any equipment malfunctions due to voltage loss on to small of a gauge of wire. WIRE PER N.E.C., C.E.C., OR LOCAL ELECTRIC CODES. Each unit is to be operated on individual circuits. Allow no more than 10 feet of exposed power cord.

### VERIFICATION OF VOLTAGE

Verify that the voltage and phase of power available matches that of the equipment.

It is recommended that you have a qualified electrical installer provide the appropriate receptacle for the fountain purchased. The single (1) phase, 230 volt Font'N-Aire Ready requires a 15 amp, 230 volt circuit. **SUPPLY A DEDICATED CIRCUIT FOR EACH FOUNTAIN.**

It is strongly recommended to check and compare the amperage and performance characteristics with the information that is provided on the envelope containing this manual and record below.



## READY FOUNTAIN

### E.L.C.I., Time Clock & Control Panel Mounting

The E.L.C.I. (Equipment Leakage Current Interrupter) is attached to a short length of cable and is connected to the Time Clock.

The Time Clock on the Font’N-Aire **Ready** is installed on the same plate to which the Franklin Electric C.R.C. Control box is mounted. The Controls for the fountain are designed to “Plug-in” to a 15amp horizontal blade (tandem) receptacle.

The E.L.C.I. may be removed for hardwiring the panel. **However** an **E.L.C.I. circuit breaker must be installed at the circuit breaker panel** for safety.

Attach the Control Panel to a suitable support, i.e., post, or wall, adjacent to 230volt power receptacle. Mount the time clock with the power supply cord protruding out of the bottom of the time clock enclosure pointing downward as well as the fountain power cable.

**! CAUTION:** If there is a probability of animals being present that could cause damage to occur to the fountain power cable that is supplied, it is suggested that at this time a protective flexible corrosion resistant conduit be implemented to minimize possible damage to the unit power cable.

### Attachment of watertight connector at the unit

STEP 1 The factory has placed **dielectric grease** in the watertight connectors to aid in the installation of the connector and to provide additional moisture resistance. **DO NOT REMOVE THIS MATERIAL!** The factory has also provided a tube of dielectric grease in the event an additional amount is required.

Insert the ”female” cable connector into the “male” connector at the fountain and tighten the connector gland nut by hand, **NO MORE THAN ONE HALFTURN** beyond the point that resistance is first noticed.

**! CAUTION:** **Over-tightening will distort the connector nut and will result in damage.**

STEP 2 After the wiring is complete, and the float is secured in the desired location and the fountain is installed into the float you may then apply power and operate the unit.



## **HOW TO SET THE TIME CLOCK**

**To set:** Turn the dial clockwise only until the time of day is indicated at the time indicator mark.

**To Program:** Program “on” times by depressing the black trippers on the outside edge of the dial toward the center of the dial until the tripper “clicks” into place and exposes the dial rim underneath. The fountain/aerator will turn on when the leading edge of the depressed tripper lines up with the time indicator mark. Each depressed black tripper will provide 15 minutes of “on” time.

**Manual Operation.** Programmed “on” times or “off” times may be manually overridden by sliding the tripper(s) that are directly over the time indicator to either the “on” or “off” position as desired. Don’t forget to reposition the trippers you moved or the timer will assume the newly set time as programmed.

## **OPERATION**

Each Font’N-Aire Ready unit is tested under operating conditions at the factory. The amperage and performance characteristics are listed on the envelope containing this **Operation and Maintenance Manual**.

**! CAUTION:**      **DO NOT OPERATE THE FOUNTAIN OUT OF THE WATER**



## Owners

### REFERENCE OF INITIAL OPERATION

Save this manual for future reference by that of the owner or service facility.

Startup Date \_\_\_\_\_ Startup Voltage \_\_\_\_\_ Startup Amperage \_\_\_\_\_

Startup Spray Height \_\_\_\_\_ Startup Spray Width (If applicable) \_\_\_\_\_

### MAINTENANCE

**Prior to performing any service, turn the power off. Be certain that the power will not come back on.**

The Font’N-Aire Ready is virtually maintenance free. We recommend that you remove the unit from the water periodically to visually inspect and clean any debris build up from the motor and pump assembly and inspect the propeller/impeller for wear.

1. Check the propeller or impeller for nicks, wear or broken blades. Replace annually.
2. Check the propeller or impeller for debris.
3. Check the electrical cable for cuts and/or abrasions in the jacketing.

#### **Franklin Electric Submersible Motors**

The motor is identified as the silver cylindrical device attached to and below the motor mount. The motor is water-lubricated and water-cooled. However, there is no circulation of water through the motor. The motor is sealed. **NO MAINTENANCE IS REQUIRED.** There are no serviceable parts. **DO NOT TAMPER WITH MOTOR OR DISASSEMBLE THE MOTOR. SUCH TAMPERING WILL BE EVIDENT AND WILL VOID THE FACTORY WARRANTY.**

Check all fasteners for proper tension. Pump body fasteners are to be tightened no more than 50 in/lbs. in a random pattern. **! Caution:** Do not over tighten as breakage may occur. The 5/16” motor mount nuts should be tightened to 85 in/lbs.



## **READY** **TROUBLE SHOOTING PROCEDURE**

Due to the extremely simple design of the Font' N-Aire Ready® fountain and minimal maintenance required there is consequently a limited amount of trouble shooting to be sought. A volt ohmmeter is required to complete the following trouble shooting checks.

**! DANGER:** Electric shock hazard. **Disconnect and lockout the electrical power before servicing.**

### **If the aerator does not start:**

- (1) Check for the correct voltage by using a voltmeter and verify that the voltage is within 10% of the nameplate rating of 230 volts. If the voltage is incorrect contact a licensed electrician or your power company.
- (2) After the correct voltage has been verified is present check for loose connections or a tripped circuit breaker.
- (3) Check for loose connections.
- (4) Inspect the power cord and motor lead with an ohmmeter check for continuity. Check for cuts causing short circuits. Replace as necessary with a new motor lead or power cable. Use the correct gauge and type for the power cable that being SOW or SEOW.

### **If the aerator runs but the overloads trip:**

- (5) Check for the correct voltage at the incoming line terminals. The voltage must be within 10% of the nameplate voltage on the motor. Contact an electrician to correct the voltage.
- (6) Within the **Ready** motor there is an automatic reset overload protection device which is sensitive to overload amperages over 9.8 amps and will cause the motor to stop operating. After the overload “cools” the motor will try to “restart”. Find the cause of the overload such as debris around the propeller or motor shaft or even a worn bearing in the motor.
- (7) A possible condition although remote is that the C.R.C. control box has defective components. Possible causes are lightning or power surges. It is best to replace the entire control box since lightning or power surges are usually catastrophic.
- (8) Check the power cable and motor lead for cuts or breaks using an ohmmeter. Never attempt to tape or splice a cable or motor lead.
- (9) There is nothing to repair on or in the Franklin the motor. If found to be defective; replace the motor if required.



**INSULATION & WINDING  
RESISTANCE VALUES**

CONDITION OF MOTOR AND LEADS	OHM VALUE	MEGOHM VALUE
A used motor which can be reinstalled.	10,000,000 ( or more)	10.0
MOTOR IN WATER. Ohm readings are for drop cable plus motor.		
A motor in the water in reasonably good condition	500,000-2,000,000	0.5-2.0
A motor which may have been damaged by lightning or with damaged leads. Do not pull aerator this reason.	20,000-500,000	0.02-0.5
A motor which definitely has been damaged or with a damaged cable. The aerator should be pulled and repairs made to the cable or the motor replaced. The motor will not fail for this reason alone, but it will probably not operate for long.	10,000-20,000	0.01-0.02
A motor which has failed or with completely destroyed cable insulation. The aerator must be pulled and the cable repaired or the motor replaced.	less than 10,000	0.0-0.1

Insulation resistance does not vary with rating. All motors of all HP, voltage, and phase rating have the same value of insulation resistance.



## **READY**

### **NOZZLE INSTALLATION AND REMOVAL**

The nozzle plenum torque values should be 50 in/lbs. If the spray pattern changes from the original configuration, inspect for and remove any foreign matter that may be present within the pump and nozzle areas. The primary location to look for these obstructions or foreign materials would be within the nozzle.

#### **CENTRIFUGAL PUMP NOZZLES**

Font'n-Aire Ready centrifugal pump units are provided with removable PVC nozzles. Font'n-Aire Ready provides this as a convenience for ease of cleaning or replacement.

The Skyward, Diana, North Star, Solace and Nova nozzles are held into the water plenum by two 10-24 x ½ inch machine screws.

The Galaxy nozzle is held in place by two 10-24 x 1 inch machine screws. It is necessary to center the Galaxy nozzle in the water plenum. This is achieved by using two nylon spacers on the 1-inch nozzle screws between the plenum wall and the nozzle, thus centering the nozzle within the plenum. Do not misplace the screws or spacers necessary for centering and holding within the plenum.

All of the **Ready** centrifugal pump unit nozzles use an o-ring to prevent leakage, replace if damaged.

#### **PROPELLER PUMP NOZZLES**

The propeller pump nozzles are held in place by two ¼-20 screws. Loosen the screws just enough to be able to turn the nozzle (Item # 22, propeller pump parts list) counter-clockwise and slide off of the throat (Item #16, propeller pump parts list)

Access to the Flow Straightener (Item #19) and propeller (Item #15) is now possible and will permit the removal of any foreign debris.

Reinstall in the reverse order of removal and tighten no more than 50 Inch/Lbs.

### **STORAGE**

Place the unit in an upright position. Do not expose to temperatures below -20°F and avoid exposure to temperatures over 120°F.

It is recommended that the fountain equipment be removed in freezing conditions. If unit is left in the water, do not allow to freeze in place. Damage to equipment could result.



## DEBRIS MANAGEMENT INFORMATION

The factory has included on Font’N-Aire **Ready**, a “shroud” to minimize the chance of debris fouling the propeller or impeller area and yet maintain a maximum flow of water past the motor.

The shroud is **only** to be considered a best-placed effort to minimize any fouling and is **not** a guarantee that foreign material will not come in contact with the moving components.

The shroud is **NOT** to be considered a safety device.

In certain situations it may be desired to add additional debris barriers to aerator or fountain equipment.

Material that should be considered for after market debris barriers are plastic or non-corrosive metal mesh materials. The material should be installed around the flotation periphery or within the unit-mounting hole located in the center of the float. Note: the threaded inserts seen on the center hole on some Air-O-Lator floats are provided as a convenience.

**DO NOT** install a bottom in this type of shroud **UNLESS** a shroud of similar material is placed on top of the flotation. The idea is to prevent “CRITTERS” from falling into the shroud area, thus becoming entrapped and then afoul of the smooth operation of the equipment.

Aerator “top of float” shroud material must be of a fine strand so that the water being delivered to the atmosphere by the aerator has minimal impingement of the water against the shroud.

Fountain “top of float” shroud material does not have the mesh size restrictions as that of the aerator. Simply cut a hole in the material to allow the nozzle to project through the hole so that the spray pattern is unimpeded.

After all this has been said it is important to realize that if a shroud **truly** is effective that the shroud will have to be cleaned just as a propeller or nozzle would in the first place. Otherwise theoretically the unit could suffer from a lack of performance or worse.





## FONT'N-AIRE "READY"

# CERTIFICATE OF LIMITED WARRANTY

2007

### 1. Your Legal Rights Under This Warranty

This warranty is the only express warranty that Air-O-Lator makes for your Air-O-Lator product. This warranty gives you specific legal rights.

This warranty is only for products sold for use in the USA.

THERE ARE NOT WARRANTIES WHICH EXTEND BEYOND THE DESCRIPTION ON THE FACE HEREOF.

This warranty will be governed by the laws of the State of Missouri, USA.

### 2. What's Covered

#### 2.1 Basic Warranty

Air-O-Lator warrants to the original purchaser that the equipment delivered by it will be of the kind and quality described in the order and will be free of defects in **workmanship, material or factory preparation** when operated under normal use and services.

##### A. What's Covered at No Cost to You

**The Basic Warranty covers the cost of all parts needed to repair any defective item on your Air-O-Lator product – that is, defective in material, workmanship, or factory preparation. Warranty repairs or adjustments – including all parts and labor connected with them – will be made at Air-O-Lator Corporation or an AUTHORIZED repair facility.**

##### B. Products Covered

**The Font'N-Aire "Ready" fountain using Franklin Electric 4" motors.**

##### C. When It Begins

The Basic Warranty begins on either of the following dates, whichever is earlier:

- The date you **take delivery** of the Air-O-Lator product or
- The date when the product was first put into service up to **24 months** from the date of manufacture.

##### D. When It Ends

The Basic Warranty lasts for **24 months** for the Font'n-Aire READY.

## E. Exceptions

Exceptions to the 24 month warranty are: **equipment used in severe environments**, which are not warranted, i.e., wastewater applications or where high concentrations of corrosive or abrasive material are present.

## F. Registration and Operation Requirements

The Basic Warranty covers your Air-O-Lator product only if:

- It was built for sale in the U.S.
- It's registered in the U.S.
- It's used in the U.S. and
- It's operated and maintained in the manner described in your Owner's Manual.

## 3. What's Not Covered

### 3.1 Modifications Not Covered

#### A. Some Modifications Don't Void this Warranty but Aren't Covered

Certain changes that you might make to your product do not, by themselves, void this warranty. Examples of some of these changes are:

- Installing non-Air-O-Lator supplied parts, components, or equipment (such as a non-Air-O-Lator supplied Franklin Electric motor, stainless steel fasteners, or fountain nozzles).

But this warranty does not cover any part that Air-O-Lator did not supply. Nor does this warranty cover the cost of any repairs or adjustments that might be caused or needed because of the installation or use of non-Air-O-Lator parts, components, equipment, or materials.

Examples of the types of alterations not covered are:

- Installing accessories – except for genuine Air-O-Lator accessories approved for installation – such as lighting, propeller guards, rock covers, or motors.
- Labor to install or remove any Air-O-Lator product.

#### B. Modifications That Will Void Your Warranty

Disconnecting, tampering with, or altering the electric control panels will void your warranty, unless you or your repairing technician follows Air-O-Lator's requirements for repairing or replacing the controls.

Removing and operating Air-O-Lator equipment without Air-O-Lator approved electrical controls will also void this warranty. Using any electric cable, connectors or splices not provided or authorized by Air-O-Lator will also void this warranty.

### 3.2 Environmental Factors Not Covered

**This warranty does not cover** damage caused by environmental factors such as, chemicals, and salt. Nor does your warranty cover damage caused by **windstorms, hailstorms, tornadoes, lightning, power surges, brownouts, floods, earthquakes debris and animals.**

### 3.3 Maintenance Costs Not Covered

This warranty does not cover the cost of repairing damage caused by poor or improper maintenance. This warranty does not cover the costs of your equipment's normal or scheduled maintenance I.e. annual propeller/impeller replacement, cleaning etc.

3.4 **Incidental and Consequential Damages Not Covered**

This warranty does not cover any incidental or consequential damages connected with Air-O-Lator products' failure, either while under warranty or afterward. Examples of such damages include:

- Lost time, Inconvenience; The loss of the use of equipment; The loss of personal or commercial property; The loss of revenue; and Delay

3.5 **Certain Kinds of Corrosion Not Covered**

This warranty does not cover the following:

- Corrosion caused by accident, damage, abuse, or alteration;
- Surface corrosion caused by such things as, sand, salt, stones and barnacles.
- Corrosion caused by the extensive or abnormal exposure of caustic materials like chemicals, acids, and fertilizers.

3.6 **Freight:**

Warranty shipping charges are to be pre-paid by the owner.

Warranty shipping charges are the responsibility of the owner.

**4. How To Get Warranty Service**

4.1 **Where to Take Your Air-O-Lator Product**

Air-O-Lator authorizes you to return your Air-O-Lator products to the factory **upon notification.**

You may contact: Air-O-Lator Corporation: 8100-04 Paseo, Kansas City, MO 64131, 1-800-821-3177.  
<http://airolator.com>

**CUSTOMER REGISTRATION COPY**

Owner Name_____	Model _____
Date Purchased_____	Serial No._____
Owner Address_____	Dealer Name_____
City_____	Address_____
State_____ Zip_____	City_____ State_____ Zip Code_____

NOTE: This information should be retained for your file.

**AIR-O-LATOR CORPORATION, 8100-04 PASEO, KANSAS CITY, MO 64131**  
**1-800-821-3177**                      [www.airolator.com](http://www.airolator.com)



THE WATER'S EDGE™

8100-04 Paseo, Kansas City, Missouri 64131  
800-821-3177

## MAIL IN FORM

# WARRANTY REGISTRATION

**Font' N-Aire Ready**

Purchase Date      Mo. \_\_\_\_\_ Day \_\_\_\_\_ Year \_\_\_\_\_

Model No. \_\_\_\_\_

Serial No. \_\_\_\_\_

Owner Name \_\_\_\_\_

Dealer Name \_\_\_\_\_

Owner Address \_\_\_\_\_

Dealer Address \_\_\_\_\_

City \_\_\_\_\_

City \_\_\_\_\_

State \_\_\_\_\_ ZIP Code \_\_\_\_\_

State \_\_\_\_\_ ZIP Code \_\_\_\_\_



## AIR-O-LATOR CORPORATION REPAIR RETURN FORM

To avoid delays in the repair of equipment in question, it is best to call the factory at 1-800-821-3177 to determine what portion or portions of the equipment in question should be returned. The fountain or aerator unit itself (that portion that sets down into the hole in the floatation) is to be returned completely assembled. **DO NOT DISASSEMBLE ANY PORTION WITHOUT PRIOR AUTHORIZATION!**

Shipping costs to and from the factory are the responsibility of the shipper as is the packaging. Air-O-Lator encourages the use of the original shipping container that is UPS approved for this equipment to minimize the possibility of shipping damage. Additional charges will apply if original packaging is not retained.

If the original packaging is not retained and used by the customer, Air-O-Lator will supply replacement packaging (at a nominal charge) upon return of the equipment to the shipper (call for current pricing).

Upon the inspection of returned equipment, whether in warranty or not, contact by Air-O-Lator to proceed with repair will be made to the owner or agent with an explanation of the repairs and charges if any. **NO REPAIRS WILL BE MADE UNLESS AUTHORIZED BY THE OWNER OR AGENT.** If Air-O-Lator is unable to contact the owner/agent within 30 days after receipt of the equipment for repair, a "signature required" notice will be forwarded to the owner or agent stating that disposal of the equipment will be made 30 days from the date of the notice.

Name \_\_\_\_\_

Address \_\_\_\_\_

Phone \_\_\_\_\_ FAX \_\_\_\_\_ E-Mail \_\_\_\_\_

E-mail \_\_\_\_\_ Equipment Serial # \_\_\_\_\_

Comments: \_\_\_\_\_

\_\_\_\_\_  
\_\_\_\_\_

FONT'N-AIRE READY  
PROPELLER PUMP PARTS LIST

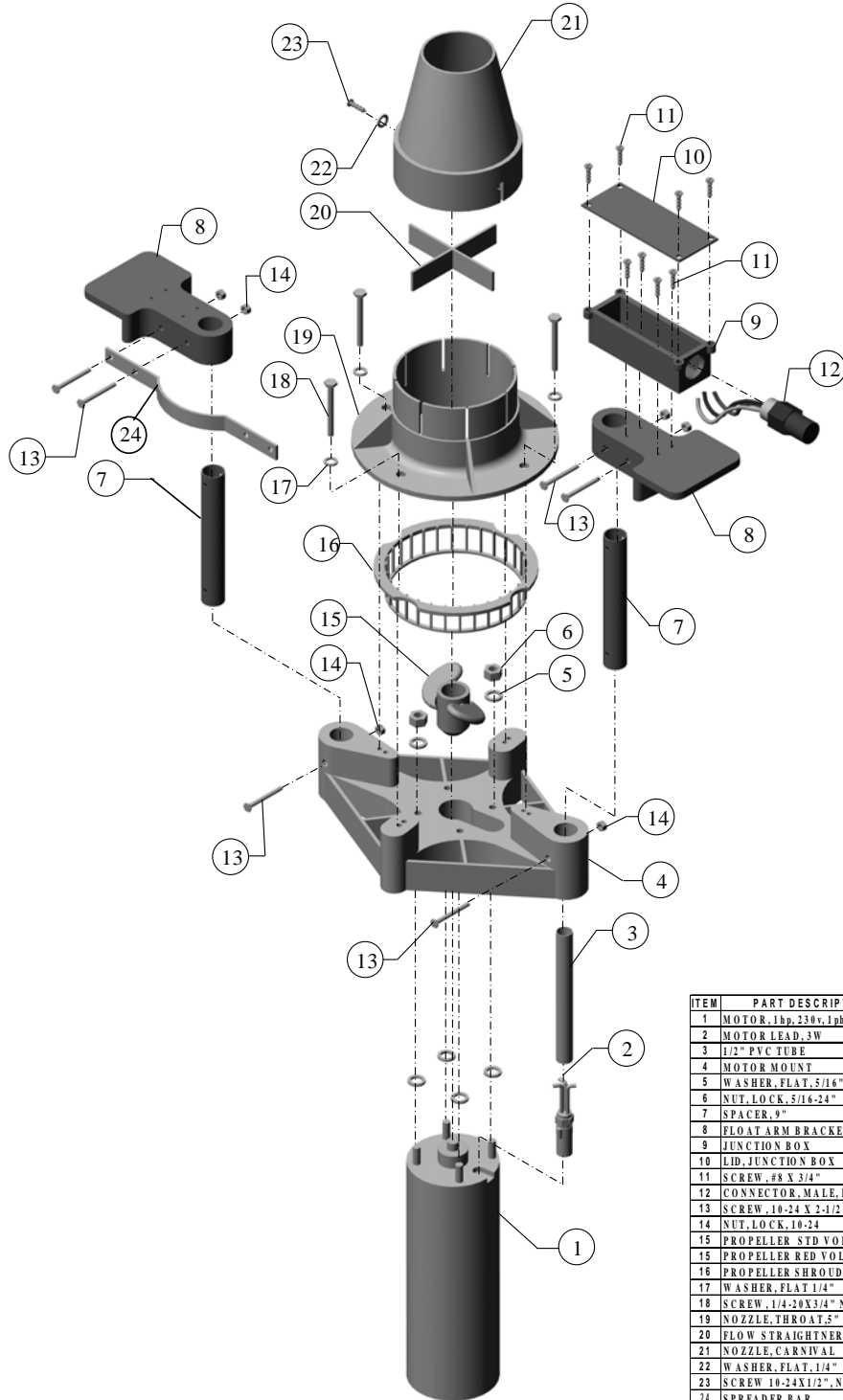

ITEM	PART DESCRIPTION	QTY	PART NUMBER
1	MOTOR, 1hp, 230v, 1ph	1	4921450812
2	MOTOR LEAD, 3W	1	58152553905
3	1/2" PVC TUBE	16"	15PVC12
4	MOTOR MOUNT	1	04MMFAM
5	WASHER, FLAT, 5/16"	4	18079025
6	NUT, LOCK, 5/16-24"	4	18078500
7	SPACER, 9"	2	85SP9
8	FLOAT ARM BRACKET	2	22FARM
9	JUNCTION BOX	1	15JBM
10	LID, JUNCTION BOX	1	15JBL-FNA
11	SCREW, #8 X 3/4"	4	183182837
12	CONNECTOR, MALE, BH	1	15CN-32681
13	SCREW, 10-24 X 2-1/2"	6	181024250
14	NUT, LOCK, 10-24	6	18071NM10
15	PROPELLER STD VOL	1	70PSV40X275
16	PROPELLER RED VOL	1	70PRV46X275
17	WASHER, FLAT 1/4"	4	18079020
18	SCREW, 1/4-20X3/4", NYLON	4	1810102575LL
19	NOZZLE, THROAT, 5"	1	04NTM
20	FLOW STRAIGHTNER	1	22FS18
21	NOZZLE, CARNIVAL	1	04NCM
22	WASHER, FLAT, 1/4"	2	18079020
23	SCREW 10-24X1/2", NYL	2	1810102550LL
24	SPREADER BAR	2	18S8BFNA

01/01/08

FONT'N-AIRE READY  
CENTRIFUGAL PUMP PARTS LIST

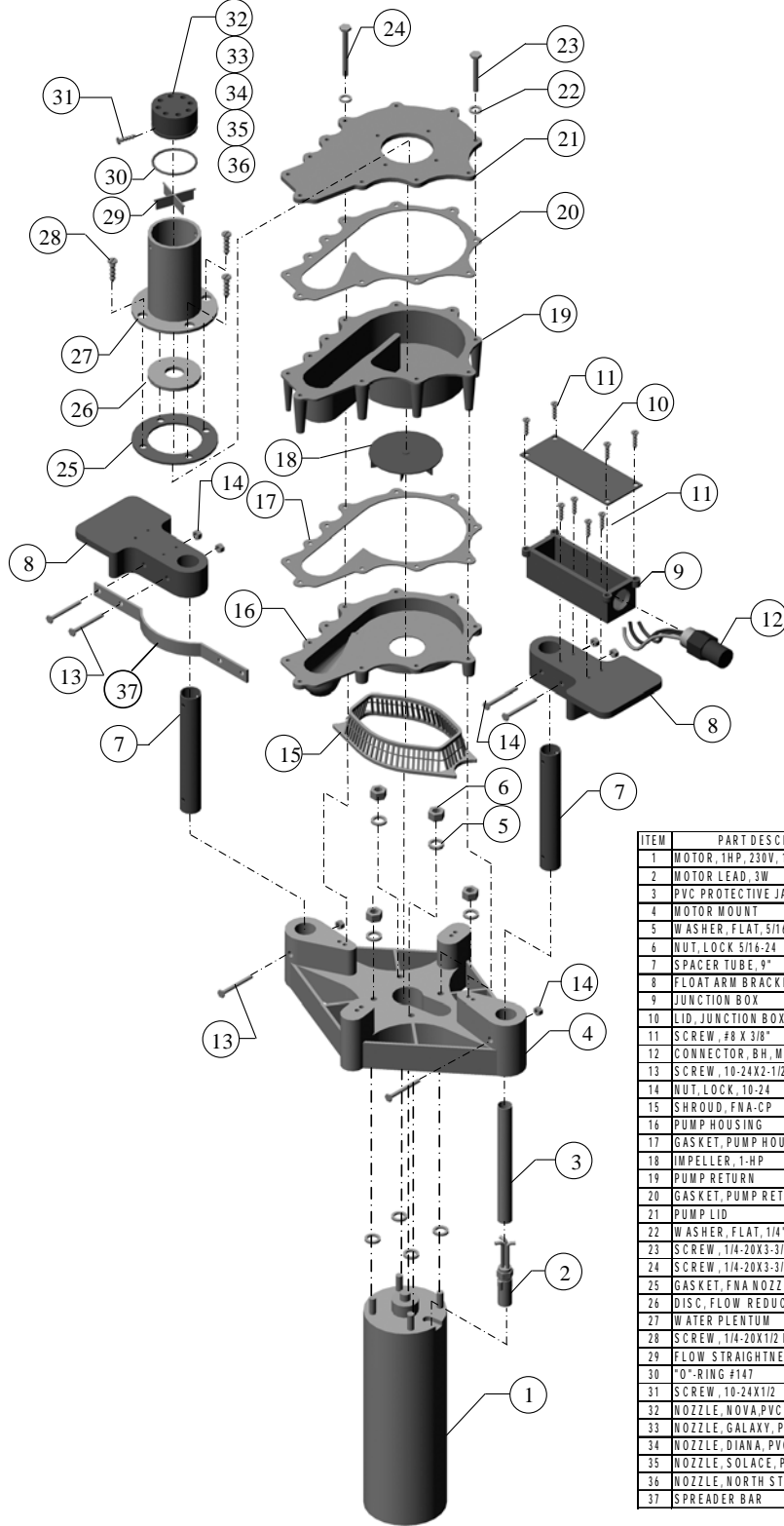

ITEM	PART DESCRIPTION	QTY	PART NUMBER
1	MOTOR, 1HP, 230V, 1PH	1	4921450812
2	MOTOR LEAD, 3W	1	58152553905
3	PVC PROTECTIVE JACKET, 16"	1	15PVC12
4	MOTOR MOUNT	1	04MMFAM
5	WASHER, FLAT, 5/16"	4	18079025
6	NUT, LOCK 5/16-24	4	18078500
7	SPACER TUBE, 9"	2	85SP9
8	FLOAT ARM BRACKET	2	22FABIM
9	JUNCTION BOX	1	15JBIM
10	LID, JUNCTION BOX	1	15JBL-FNA
11	SCREW, #8 X 3/8"	8	183182837
12	CONNECTOR, BH, MALE	1	15CN-32681
13	SCREW, 10-24X2-1/2"	6	181024250
14	NUT, LOCK, 10-24	6	18071NM10
15	SHROUD, FNA-CP	1	70PGFNACP
16	PUMP HOUSING	1	64PH-PIMG
17	GASKET, PUMP HOUSING	1	64PHG2
18	IMPELLER, 1-HP	1	70CPIM1
19	PUMP RETURN	1	64PR-PIMG
20	GASKET, PUMP RETURN	1	64PRG2
21	PUMP LID	1	64PRL-PIMG
22	WASHER, FLAT, 1/4"	11	18079020
23	SCREW, 1/4-20X3-3/4" W/LOCK	7	18101025275LL
24	SCREW, 1/4-20X3-3/4" W/LOCK	4	18101025375LL
25	GASKET, FNA NOZZLE	1	64GFN
26	DISC, FLOW REDUCTION	1	64FRD
27	WATER PLENTUM	1	64WPCP
28	SCREW, 1/4-20X1/2 NYLON	4	1810102550LL
29	FLOW STRAIGHTNER (CP)	1	64FSCP
30	O-RING #147	1	29OR147
31	SCREW, 10-24X1/2	2	18032200
32	NOZZLE, NOVA, PVC	1	67MPVCONOV
33	NOZZLE, GALAXY, PVC	1	67MPVCGAL
34	NOZZLE, DIANA, PVC	1	67MPVCDI
35	NOZZLE, SOLACE, PVC	1	67MPVCSOL
36	NOZZLE, NORTH STAR, PVC	1	67MPVCNST
37	SPREADER BAR	2	18SBFNA

1/1/08



**INSTRUCTIONS FOR THE READY & PLATINUM 12-VOLT LIGHT KIT**  
**8/1/08**

STEP 1 Place float on a flat surface with the molded pockets facing upward (see photo below).



STEP 2 Locate and remove from shipping carton the light assembly with the four (4) light housings. Locate the light housing that has the 12-volt electrical connector (see photo below).



STEP 3 Position the light housing with the 12-volt electrical connector into the float light housing pocket, which has the cable groove which angles toward the Power Pack pocket.

STEP 3A It will be necessary to remove each sealed beam from each light housing. To do so, grip the sealed beam retaining ring tang on the housing that has the 12-volt connector and squeeze to remove. **CAUTION:** The retaining ring is under tension. Use caution upon removal to prevent any sudden release of tension that may pinch or cause flying of the retaining ring from your grasp resulting in injury.

STEP 3B Notice that the float light housing pockets are partially angled and partially horizontal. The horizontal position is for the vertical jet fountain units. The angled position is for the arching spray units. Select which position is appropriate for the unit you ordered and fasten the light housing with the screw provided. Reinstall the sealed beam and secure in

place with the retaining ring. Remember to use caution to prevent possible injury from the retaining ring.

- STEP 4 Position the remaining three (3) light housings in sequence into the light housing pockets around the float with the electrical cord placed in the cable grooves. Secure each light housing in the same manner as described in Step 3.



Power Pack Mounting:

- STEP 5 Place the 12-volt light Power Pack into the 6" wide x 8" long x 2" deep pocket in the corner of the float adjacent to the Air-O-Lator logo and align elongated hole of the Power Pack Mounting Bracket tang Item #12 with the threaded insert nearest the Power Pack pocket and insert the  $\frac{3}{4}$  long  $\frac{1}{4}$  - 20 screw provided into the provided flat washer Item#11. Insert this screw and washer assembly into the tang and tighten securely with a Phillips screw driver.

- STEP 6 **LOCATE THE TUBE OF DIELECTRIC SILICONE GREASE TO BE FOUND IN THIS ENVELOPE.**

Dielectric silicone grease is provided to primarily to assist insertion of the connectors into the appropriate sockets and to secondarily minimize the possibility of moisture intrusion.

- STEP 7 Connect the 12-volt electrical cable (small yellow cable) to the Power Pack. Insure that dielectric silicone grease is evident on the connector!

- STEP 8 **COUNTER WEIGHT:** It is necessary to install a counter-weight (supplied) to offset the weight of the Power Pack. Locate the round pocket on the bottom side of the float (side opposite the Air-O-Lator logo) to receive the counter-weight. Secure the counter-weight to the float by the 5/16-18 x 1" hex machine screw supplied with the weight.

- STEP 9 Position the fountain float arms into the float arm recesses of the flotation platform so that the junction box of the fountain unit is on the same side of the float as that of the Power Pack.

## POWER PACK WIRING CONNECTIONS

### **BE CERTAIN THE ELECTRIC POWER IS TURNED OFF!**

Place dielectric silicone grease in the female connector socket to be found on one end of the yellow 2 foot interconnecting cable that is to run between the Power Pack and the fountain . The cable (male end) is to be connected at the lighting Power Pack female connector. Hand-tighten no more than one half turn beyond the point that the connector indicates resistance.

At this time insure that dielectric silicone grease is evident in the fountain junction box (male connector). The opposite end of the yellow cable the (female end) is to be connected to the fountain junction box male connector on the fountain. Hand-tighten no more than one half turn beyond the point that the connector indicates resistance.

At this time insure that dielectric silicone grease is evident on the female connector on the power supply cable.

You may now safely connect the power supply cable that runs from the fountain controls to the Power Pack.

**CAUTION:** Do not over-tighten any cable connectors as distortion can occur and cause damage to the connectors.

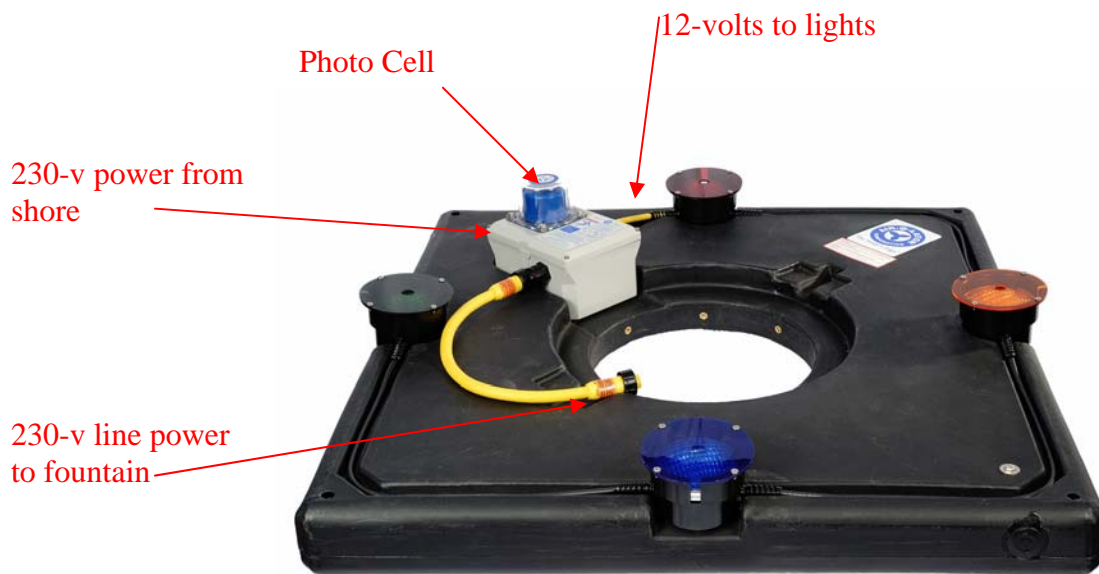

STEP 10 Position the fountain in the desired location and anchor as was shown on page two Step (1) “Mooring of Float”.

STEP 11 Connect the shore power supply to the transformer power pack (line voltage in). When safe to do so, apply power and enjoy your fountain.

## **LIGHT KIT MAINTENANCE**

### **THE POWER PACK IS FACTORY RATED FOR SUBMERGENCE**

**As required in the National Electric Code ARTICLE 680.52 (B2) & 680.10.**

### **THE POWER PACK ENCLOSURE IS SEALED.**

**DO NOT ATTEMPT TO OPEN OR ATTEMPT TO REPAIR THE POWER PACK. RETURN THE POWER PACK TO THE FACTORY FOR SERVICE OR REPAIR.**

The main supply voltage to the fountain equipment is reduced to 12-volts by means of a hermetically sealed transformer within the Power Pack enclosure. There is no maintenance required on the transformer or any of the contents of the power pack enclosure.

## **PHOTO CELL REPLACEMENT**

Remove the four screws that retain the photo cell water shield cover and gasket. Save and set these items aside to await reinstallation.

Twist the original photo cell counter clockwise and extract from the Socket and discard the original photo cell.

Insert the replacement photo cell into the socket and turn until resistance is determined.

Place the gasket on top of the Power Pack cover as it was before it was removed and insert the four screws into the photo cell water shield cover and tighten to a value of: 50 – 55 in/lbs.

## **COLORED LENS INSTALLATION / REPLACEMENT**

STEP 1 To install a colored lens, shut off the power and place the colored lens on the light-housing flange, aligning the holes on the lens with the holes on the flange. Install (4) lens cover retaining pins through the holes.

## **SEALED BEAM REPLACEMENT**

STEP 1 Remove the colored lens (if attached), locate the sealed beam retaining spring; squeeze the tangs, lift and remove. Caution: The retaining spring is under tension. Do not lose your grip, as you may injure yourself or lose the retaining spring.

STEP 2 Remove sealed beam (a piece of masking tape or small suction cup may be of assistance).

STEP 3 Detach the wire connectors and reattach to the new sealed beam, install in reverse order.

## **END OF 12-V LIGHT KIT INSTRUCTION**

## **FONT'N-AIRE LIGHT KIT LIMITED WARRANTY**

If within **one (1) year** from the date of purchase, this Low Voltage Lighting fails due to a defect in **material** or **workmanship**, Air-O-Lator Corporation will repair or replace any unusable or inoperative part if the **“POWER PACK”** is returned to the factory, **freight prepaid**, to Air-O-Lator, upon prior notification.

The warranty **does not apply** to (a) **damaged caused by accident, abuse, mishandling, dropping;** (b) **lighting systems that have been subject to unauthorized repair, opened transformers, taken apart;** (c) **not used in accordance with instructions;** (d) **or damages.**

**Air-O-Lator is not liable for incidental or consequential damages.** Some states do not allow a limitation of damage, therefore, the foregoing limitation may not apply to you. This warranty gives you specific legal rights, and you may have other rights that vary from state to state.

Warranty service is available by contacting your dealer or by contacting the factory before return. If the product is returned for repair, the light kit must be returned prepaid. This warranty is express or limited and this warranty is made by Air-O-Lator Corporation of Kansas City, Missouri 64131.

LIGHT KIT ASSEMBLY PARTS LIST  
94LK120206, 120 VOLT, 2 WIRE

LIGHT STRING ASSEMBLY 90LA50CWF (ITEMS 1-8)			
ITEM	PART DESCRIPTION	QTY	PART NUMBER
1	CONN., BH., 12-VOLT, MALE	1	15CN-40904
2	STRAIN RELIEF LIGHT HOUSING	7	15SR-1611
3	LIGHT HOUSING, GLV80	4	04LH4GLV80
4	WIRE ASSY. LIGHT KIT, 14/2 (43")	3	90WALK43
5	HALOGEN SEAL BEAM 50 WATT, 12 VOLT WIDE	4	15LB50HWFL
6	SEAL BEAM RETAINING RING, SS	4	90SBRR
OPTIONAL			
7	LENS COVER (RED)	1	15LCRD
7	LENS COVER (GREEN)	1	15LCGR
7	LENS COVER (BLUE)	1	15LCBL
7	LENS COVER (AMBER)	1	15LCAM
8	LENS RETAINING FASTNER	4	1832621037

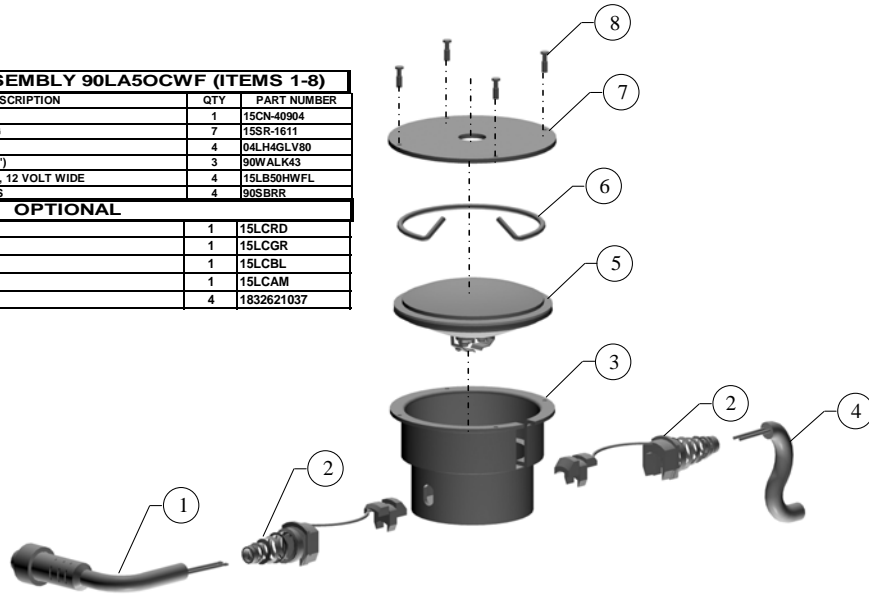

LIGHT TRANSFORMER ASSEMBLY 90TXA120206 (ITEMS 1-12)			
ITEM	PART DESCRIPTION	QTY	PART NUMBER
1	TRANSFORMER PACK, 120-12, 2W	1	90TP120206
2	CONN., BH., 3/4" DOUBLE ENDED	1	15CN-6F020
3	PHOTO CELL SOCKET	1	15PC-K122
4	GASKET, WATER SHIELD	1	29GWSC
5	PHOTO CELL	1	15PC5007S
6	WATER SHIELD COVER	1	04WSC
7	WASHER, 1/4", FLAT	4	18079020
8	SCREW, HHCS, 1/4-20X1/2	4	1810102550LL
9	POWER PACK MOUNTING BRACKET	1	15MBLT
10	SCREW, 1/4-20X1/2" PHILLIPS HEAD	4	1830622550LL
11	WASHER, 1/4", FLAT	5	18079020
12	SCREW, 1/4-20X3/4" PHILLIPS HEAD	1	1830622575LL

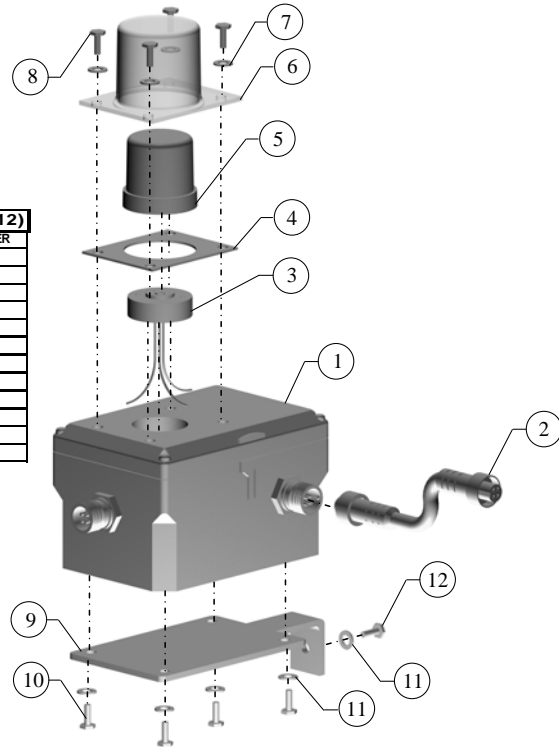

8-11-08

LIGHT KIT ASSEMBLY PARTS LIST  
94LK230206, 230 VOLT, 2 WIRE

LIGHT STRING ASSEMBLY 90LA5OCWF (ITEMS 1-8)			
ITEM	PART DESCRIPTION	QTY	PART NUMBER
1	CONN., BH, 12-VOLT, MALE	1	15CN-40904
2	STRAIN RELIEF LIGHT HOUSING	7	15SR-1611
3	LIGHT HOUSING, GLV80	4	04LH4GLV80
4	WIRE ASSY. LIGHT KIT, 14/2 (43")	3	90WALK43
5	HALOGEN SEAL BEAM, 50 WATT, 12 VOLT NARROW	4	15LB50HNSP
6	SEAL BEAM RETAINING RING, SS	4	90SBRR

OPTIONAL			
ITEM	PART DESCRIPTION	QTY	PART NUMBER
7	LENS COVER (RED)	1	15LCRD
7	LENS COVER (GREEN)	1	15LCGR
7	LENS COVER (BLUE)	1	15LCBL
7	LENS COVER (AMBER)	1	15LCAM
8	LENS RETAINING FASTNER	4	1832621037

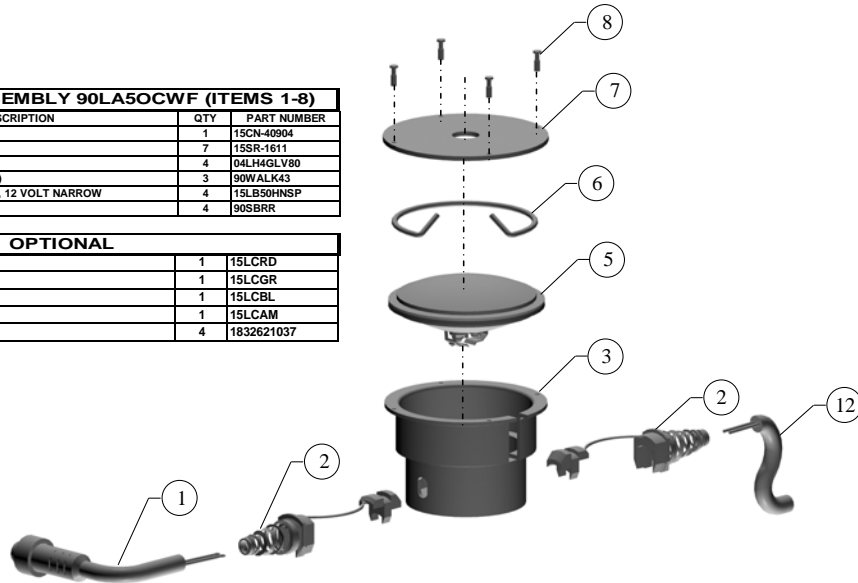

LIGHT TRANSFORMER ASSEMBLY 90TXA230206 (ITEMS 1-12)			
ITEM	PART DESCRIPTION	QTY	PART NUMBER
1	TRANSFORMER PACK, 230-12, 2W	1	90TP230206
2	CONN., BH., 3/4" DOUBLE ENDED	1	15CN-6F020
3	PHOTO CELL SOCKET	1	15PC-K122
4	GASKET, WATER SHIELD	1	29GWSC
5	PHOTO CELL	1	15PC5007S
6	WATER SHIELD COVER	1	04WSC
7	WASHER, 1/4", FLAT	4	18079020
8	SCREW, HHCS, 1/4-20X1/2	4	1810102550LL
9	POWER PACK MOUNTING BRACKET	1	15MBLT
10	SCREW, 1/4-20X1/2" PHILLIPS HEAD	4	1830622550LL
11	WASHER, 1/4" FLAT	5	18079020
12	SCREW, 1/4-20X3/4" PHILLIPS HEAD	1	1830622575LL

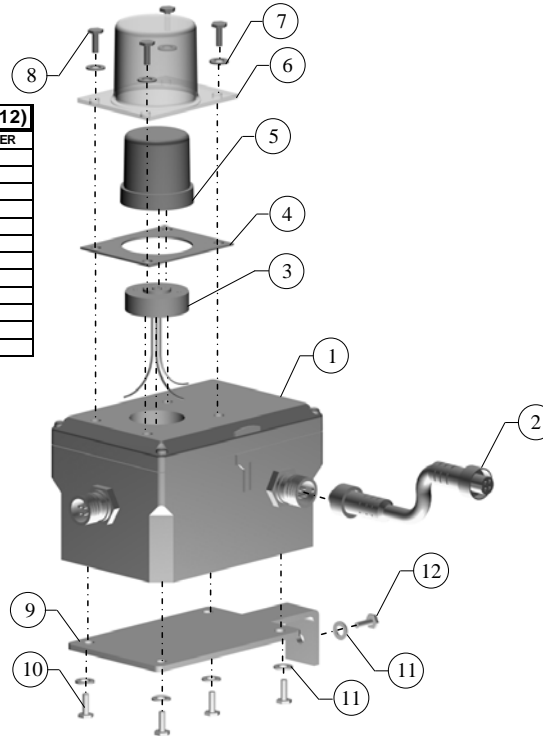

8-11-08

LIGHT KIT ASSEMBLY PARTS LIST  
94LK230306, 230 VOLT, 3 WIRE

LIGHT STRING ASSEMBLY 90LA50CWF (ITEMS 1-8)			
ITEM	PART DESCRIPTION	QTY	PART NUMBER
1	CONN., BH., 12-VOLT, MALE	1	15CN-40904
2	STRAIN RELIEF LIGHT HOUSING	7	15SR-1611
3	LIGHT HOUSING, GLV80	4	04LH4GLV80
4	WIRE ASSY. LIGHT KIT, 14/2 (43")	3	90WALK43
5	HALOGEN SEAL BEAM 50 WATT, 12 VOLT WIDE	4	15LB50HWFL
6	SEAL BEAM RETAINING RING, SS	4	90SBRR
OPTIONAL			
7	LENS COVER (RED)	1	15LCRD
7	LENS COVER (GREEN)	1	15LCGR
7	LENS COVER (BLUE)	1	15LCBL
7	LENS COVER (AMBER)	1	15LCAM
8	LENS RETAINING FASTNER	4	1832621037

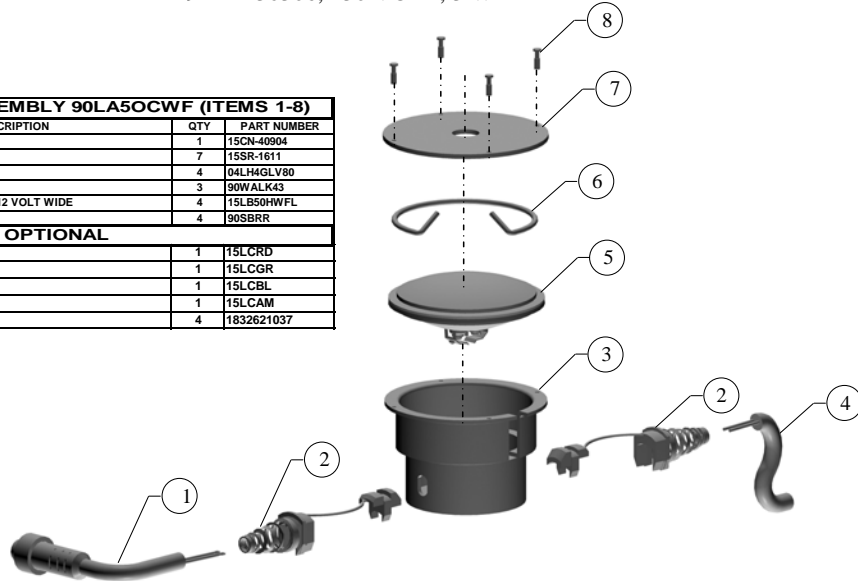

LIGHT TRANSFORMER ASSEMBLY 90TXA230306 (ITEMS 1-12)			
ITEM	PART DESCRIPTION	QTY	PART NUMBER
1	TRANSFORMER PACK, 230-12, 3W	1	90TP230306
2	CONN., BH., 3/4" DOUBLE ENDED	1	15CN-6F020
3	PHOTO CELL SOCKET	1	15PC-K12Z
4	GASKET, WATER SHIELD	1	29GWSC
5	PHOTO CELL	1	15PC5007S
6	WATER SHIELD COVER	1	04WSC
7	WASHER, 1/4", FLAT	4	18079020
8	SCREW, HHCS, 1/4-20X1/2	4	1810102550LL
9	POWER PACK MOUNTING BRACKET	1	15MBLT
10	SCREW, 1/4-20X1/2" PHILLIPS HEAD	4	1830622550LL
11	WASHER, 1/4", FLAT	5	18079020
12	SCREW, 1/4-20X3/4", PHILLIPS HEAD	1	1830622575LL

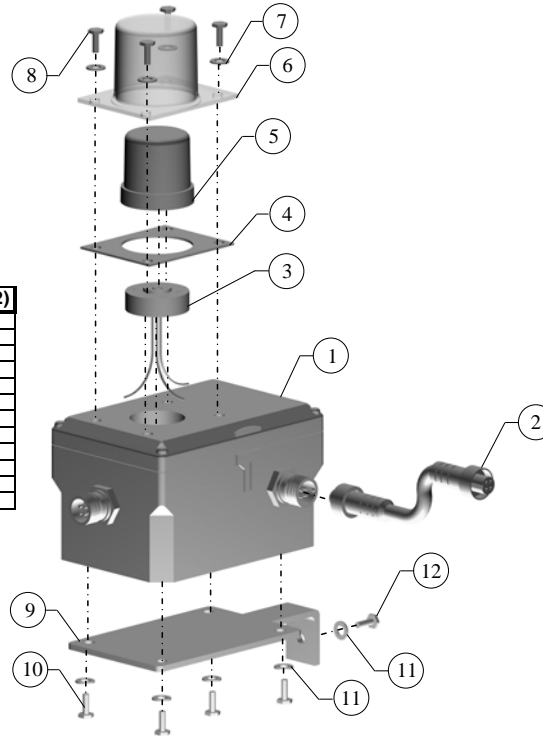

8-11-08