

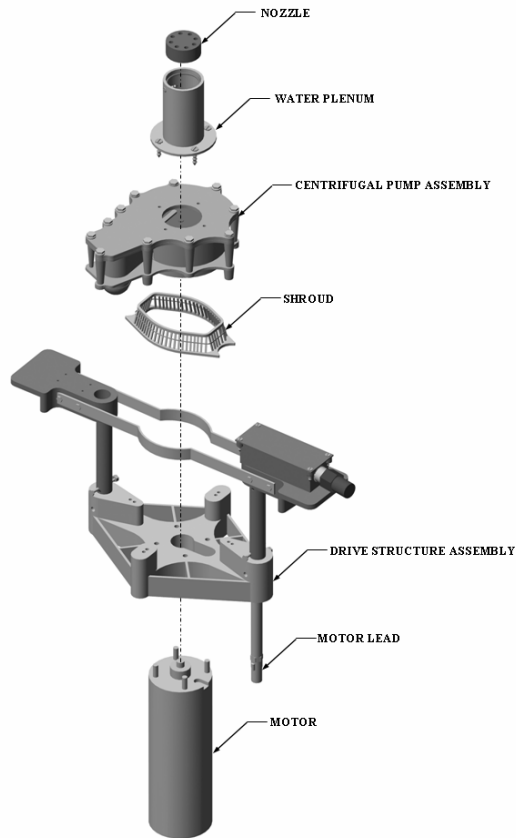

THE WATER'S EDGE™

CENTRIFUGAL PUMP NOZZLE OR WATER PLENUM REPLACEMENT



!WARNING: RISK OF ELECTRIC SHOCK, DISCONNECT POWER PRIOR TO SERVICING

STEP 1 Place the fountain upright with the motor resting on a stable surface. CAUTION: Do not allow the unit to fall over as damage may occur.

STEP 2 Remove the two 10-24 machine screws located on both sides of the water plenum.

STEP 3 Pull upwards on the nozzle to remove from the water plenum.

STEP 4 Inspect the flow straightener inside the water plenum and remove any debris.

STEP 5 Install new nozzle by aligning holes of nozzle to water plenum. Push down on nozzle until it stops, secure with two 10-24 machine screws.

STEP 6 To remove the water plenum, remove the four 1/4-20 hex head cap screws from the flange of the water plenum. Remove the plenum and gasket from the pump lid. Remove any debris that is present.

STEP 7 Install new gasket and water plenum with the four 1/4-20 hex head cap screws.