



**INSTALLATION
OPERATION
AND
MAINTENANCE
OF THE
AQUARIAN AQUACULTURE AERATORS**

DO NOT DESTROY!

This manual is designed for your use in the installation, operation and maintenance of your Aquarian aerator, please do not dispose of this manual.

The following information is provided to alert persons to potential personal injury hazards inherent with products.

! DANGER: Indicates an eminently hazardous situation which, if not avoided, will result in death or serious injury.

! WARNING: Indicates a potentially hazardous situation which, if not avoided, could result in death or serious injury.

! CAUTION: Indicates a potentially hazardous situation, which may result in minor or moderate injury.

January 1, 2005



SAFETY DATA INFORMATION SHEET

- ! DANGER:** RISK OF ELECTRIC SHOCK. DO NOT INSTALL THIS EQUIPMENT IN SWIMMING AREAS. THIS EQUIPMENT HAS NOT BEEN INVESTIGATED FOR USE IN SWIMMING AREAS.
- ! WARNING:** DISCONNECT AND LOCK OUT ELECTRICAL POWER BEFORE ANY SERVICE IS PERFORMED ON THIS DEVICE.
- ! WARNING:** THE CONTROL PANEL AND UNIT MUST BE GROUNDED. FAILURE TO CONNECT TO A PROPER GROUND COULD RESULT IN PERSONAL INJURY OR DEATH.
- ! WARNING:** BEFORE ATTEMPTING TO INSTALL, SERVICE OR MAINTAIN THE UNIT AND/OR FLOTATION IN ANY BODY OF WATER A COAST GUARD APPROVED PERSONAL FLOTATION DEVICE (PFD, TYPE III OR HIGHER) MUST BE WORN.
- ! WARNING:** THE FLOTATION PROVIDED FOR THIS EQUIPMENT, HAS NOT BEEN INVESTIGATED PERSONAL FLOTATION DEVICE.
- ! WARNING:** ATTEMPTING TO INSTALL OR SERVICE EQUIPMENT FROM AN UNSTABLE WORK PLATFORM COULD RESULT IN DEATH OR INJURY.
- ! WARNING:** POSSIBLE CUTTING HAZARD. ROTATING PROPELLER COULD RESULT IN SERIOUS INJURY. TURN OFF POWER AND LOCK OUT BEFORE INSTALLATION OR SERVICING.
- ! NOTICE:** *DO NOT OPERATE THIS EQUIPMENT OUT OF THE WATER. (EXCEPTION:;) IT IS PERMISSABLE TO BUMP RUN 3-PHASE EQUIPMENT OUT OF THE WATER TO VERIFY COUNTER CLOCKWISE MOTOR ROTATION WITH A RAPID ON/OFF OPERATION.*
- ! CAUTION:** INSTALLATION OR SERVICE WORK MUST BE PERFORMED FROM A STABLE WORK PLATFORM TO AVOID THE POSSIBILITY OF CAPSIZING.



REMOVE THE AQUARIAN AQUACULTURE UNIT FROM THE SHIPPING CONTAINER. INSPECT FOR ANY SHIPPING DAMAGE.

Do not dispose of the shipping container and packing material. SAVE in the unlikely event of return for service.

STEP 1 Insert the support tube (C) into the diffuser/motor assembly (B); center the diffuser on the tube. Insert one (1) screw into the hole provided in the support tube just outside the diffuser. Install the second screw on the other side of the diffuser, in the hole provided in the support tube.

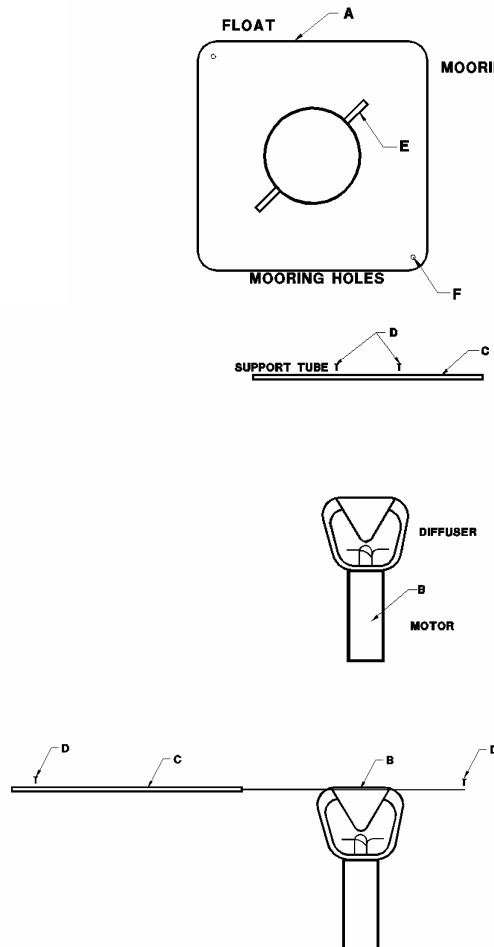



MOORING

! WARNING: DO NOT USE AS A PERSONAL FLOTATION DEVICE.

Cut two (2) lengths of 1/4" hollow braid rope or similar material of sufficient length to accommodate for the variations in the water that naturally occur. A ratio of a water level to rope of 2 - 3 to 1 should suffice.

Use (2) locally obtained concrete 8"X8"X16" building blocks as the anchor medium. Insert one of the ropes into one hole of the float and tie a knot of sufficient size that will not allow the knot to "pull out" of the float. Do the same with the other rope at a diagonal corner.

Tie the opposite end of the ropes to separate blocks in a secure manner and place on top of the float.

Position the float where desired and drop one anchor block and then the other at an angle to the float. (See the diagram below)

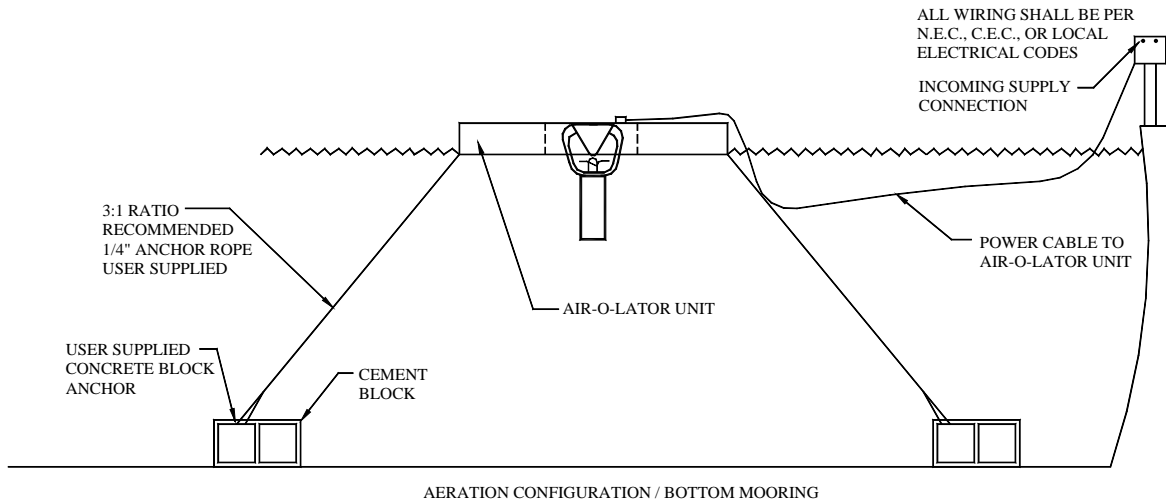

Place the Aquarian into the float (A) with the support tube (C) resting in the molded groove (E) in the float as indicated. The power cord is to rest on top of the float to minimize the possibility of entanglement with the propeller.

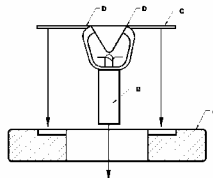

! WARNING: POSSIBLE CUTTING HAZARD. ROTATING PROPELLER COULD RESULT IN SERIOUS INJURY. TURN OFF POWER BEFORE SERVICING.

An alternative to anchoring would be to moor the unit to the shore at any point that you desire.



ICE MELTING

The Aquarian Aquaculture aerator is also capable of preventing ice formation or the melting of existing ice. The unit, however, should be lowered to approximately a five-foot depth to bring the warmer water to the surface thus preventing the formation or melting of existing ice. Air-O-Lator has depth extension kits available for immediate shipment

ELECTRICAL

! DANGER: ELECTRIC SHOCK HAZARD. DISCONNECT ELECTRICAL POWER BEFORE SERVICING PANEL OR EQUIPMENT.

! WARNING: TO REDUCE THE RISK OF ELECTRIC SHOCK CONNECT ONLY TO A PROPERLY GROUNDED CONNECTION. FAILURE TO CONNECT TO A PROPER GROUND COULD RESULT IN PERSONAL INJURY.

The single (1) phase, ½-hp, 115-volt AQ-5 requires a 15 amp, 115-volt receptacle. The single (1) phase, ½-hp, 230-volt AQ-5 and the 1-hp AQ-10 require a 15 amp, 230-volt receptacle. It is permissible to “hard wire” the unit to the power connection.

Control box mounting (AQ-10, ONLY): Remove the cover to control box. Mount the control box to any solid object, i.e., wall, posts, or struts using the holes provided. The panel must be mounted so that the electrical wires are downward. **DO NOT ALLOW THE ELECTRICAL CONTROL BOX TO LAY ON THE GROUND.**

! WARNING: CONNECT TO A GROUNDED OUTLET OR CONNECTION ONLY. Failure to do so may result in personal injury. GROUND FAULT PROTECTION is strongly suggested on ANY electrical device. **DO NOT INSTALL OR USE THIS DEVICE IN SWIMMING AREAS. This equipment has not been evaluated for use in swimming areas.**

MAINTENANCE

The Aquarian aerators are virtually maintenance free. It is recommended that you remove the unit from the water periodically to inspect, clean and remove build up on the motor. The motor is identified as the cylindrical device attached to and below the diffuser. The motor is water-lubricated and cooled. There is no circulation of water through the motor. It is sealed. **NO SEAL OR FLUID MAINTENANCE IS REQUIRED.** There are no user serviceable parts within. **DO NOT TAMPER WITH THE MOTOR OR DISASSEMBLE THE MOTOR. SUCH TAMPERING WILL BE EVIDENT AND WILL VOID THE WARRANTY.**

Inspect the propeller a minimum of **Two** times a year for wear and replace if any wear is indicated. Propeller wear can promote premature motor failure.



DEBRIS MANAGEMENT INFORMATION

The factory has included on Aquarian Commercial aerators, Ready 2000, Font’N-Aire and Gulf Stream fountains a “shroud” to minimize the chance of debris fouling the propeller or impeller area and yet maintain a maximum flow of water past the motor.

Add-on shrouds may be purchased for the Aquarian Residential and the Aquarian Aquaculture equipment. There is no shroud for the Quantum aerator.

The shroud is **only** to be considered a best-placed effort to minimize any fouling and is **not** a guarantee that foreign material will not come in contact with the moving components.

The shroud is **NOT** to be considered a safety device.

In certain situations it may be desired to add additional debris barriers to aerator or fountain equipment.

Material that should be considered for after market debris barriers are plastic or non-corrosive metal mesh materials. The material should be installed around the flotation periphery or within the unit-mounting hole located in the center of the float. Note: the threaded inserts seen on the center hole on some Air-O-Lator floats are provided as a convenience.

DO NOT install a bottom in this type of shroud **UNLESS** a shroud of similar material is placed on top of the flotation. The idea is to prevent “CRITTERS” from falling into the shroud area, thus becoming entrapped and then afoul of the smooth operation of the equipment.

Aerator “top of float” shroud material must be of a fine strand so that the water being delivered to the atmosphere by the aerator has minimal impingement of the water against the shroud.

Fountain “top of float” shroud material does not have the mesh size restrictions as that of the aerator. Simply cut a hole in the material to allow the nozzle to project through the hole so that the spray pattern is unimpeded.

After all this has been said it is important to realize that if a shroud **truly** is effective that the shroud will have to be cleaned just as a propeller or nozzle would in the first place. Otherwise theoretically the unit could suffer from a lack of performance or worse.

THE CHOICE IS YOURS.



STORAGE

Place unit in an upright position. Protect the unit from exposure to temperatures below -20°F and avoid exposure to temperatures over 120°F.

The most desired method of storing the unit would be to leave it in the pond or lake, as long as the unit is not allowed to freeze in, which could result in damage to the float or the unit.

Franklin Electric Submersible Motor Specifications (60 Hz)

| Motor | | | | Maximum | | Line to Line | S.F. | Circuit Breaker | Fuse |
|--------------|------|-------|-------|-----------------------|-------|---------------------------------|---------------|----------------------|------------------------|
| Model Number | H.P. | Volts | S. F. | S.F.Amps | Watts | Resistance | PowerFactor % | Amp Size Standard | Amp Size Time Delay |
| 244301 | 0.5 | 115 | 1.6 | 12.0 | 1000 | 1.0-1.3 | 73.00% | 35 | 20 |
| 224302 | 0.5 | 230 | 1.6 | 6.0 | 1000 | 4.2-4.5 | 73.00% | 20 | 10 |
| 214508 | 1 | 230 | 1.4 | Y 9.8 B 9.8 R 0 | 1500 | 2.2-2.7 Main 10.1-12.3 Start | 74.00% | 30 | 20 |

Cable Selection Guide

Single Phase, Three Wire with ground cable, 60 Hz
(Maximum length in feet – Service entrance to fountain)

| HP | Volts | 12 | 10 | 8 |
|-----|-------|-----|------|------|
| 0.5 | 115 | 150 | 250 | 350 |
| 0.5 | 230 | 650 | 1000 | 1600 |
| 1 | 230 | 400 | 600 | 950 |



TROUBLE SHOOTING PROCEDURE

Due to the extremely simple design of the Aquarian® Aquaculture® aerator and minimal maintenance required there is consequently a limited amount of trouble shooting to be sought. A volt ohmmeter is required to complete these checks.

! DANGER: Electric shock hazard. Disconnect and lockout the electrical power before servicing.

If the aerator does not start:

- (1) Check for the correct voltage by using a voltmeter and verify that the voltage is within 10% of the nameplate rating. If the voltage is incorrect contact a licensed electrician or your power company.
- (2) If the correct is present check for the correct size of fuses, loose connections or a tripped circuit breaker. Replace the fuses with the correct size and rating or reset the circuit breaker. If the problem persists contact your electrician.
- (3) In the case of single-phase equipment check for loose connections or overload breakers of which there are two (located on the bottom of the control box) that may have tripped and push to reset.
- (4) Inspect the power cord and motor lead with an ohmmeter check for continuity. Check for cuts causing short circuits. Replace as necessary with a new motor lead or power cable. Use the correct gauge and type for the power cable that being SOW or SEOW.

If the aerator runs but the overloads trip:

- (5) Check for the correct voltage at the incoming line terminals. The voltage must be within 10% of the nameplate voltage. Contact the power company to correct the voltage.
- (6) Overloads are heat sensitive and can trip if a control box is exposed to an excessive amount of ambient heat. Shade or move the control box away from the heat source.
- (7) A possible condition although remote is that a control box has defective components or is defective. Possible causes are lightning or power surges. Repair or replace the defective components or the entire control box as required.
- (8) Check the power cable and motor lead for cuts or breaks using an ohmmeter. Never attempt to tape or splice a cable or motor lead.
- (9) The motor may be defective. There is nothing to repair in the motor. If found to be defective; replace the motor if required.



THE WATER'S EDGE™

**INSULATION
&
WINDING
RESISTANCE
VALUES**

| CONDITION OF MOTOR AND LEADS | OHM VALUE | MEGOHM VALUE |
|--|-----------------------|--------------|
| A used motor which can be reinstalled. | 10,000,000 (or more) | 10.0 |
| MOTOR IN WATER. Ohm readings are for drop cable plus motor. | | |
| A motor in the water in reasonably good condition | 500,000-2,000,000 | 0.5-2.0 |
| A motor which may have been damaged by lightning or with damaged leads. Do not pull aerator this reason. | 20,000-500,000 | 0.02-0.5 |
| A motor which definitely has been damaged or with a damaged cable. The aerator should be pulled and repairs made to the cable or the motor replaced. The motor will not fail for this reason alone, but it will probably not operate for long. | 10,000-20,000 | 0.01-0.02 |
| A motor which has failed or with completely destroyed cable insulation. The aerator must be pulled and the cable repaired or the motor replaced. | less than 10,000 | 0.0-0.1 |

Insulation resistance does not vary with rating. All motors of all HP, voltage, and phase rating have the same value of insulation resistance.



CERTIFICATE OF LIMITED WARRANTY

2004

1. Your Legal Rights Under This Warranty

This warranty is the only express warranty that Air-O-Lator makes for your Air-O-Lator product. This warranty gives you specific legal rights.

This warranty is only for products sold for use in the USA.

THERE ARE NOT WARRANTIES WHICH EXTEND BEYOND THE DESCRIPTION ON THE FACE HEREOF.

This warranty will be governed by the laws of the State of Missouri, USA.

2. What's Covered

2.1 Basic Warranty

Air-O-Lator warrants to the original purchaser that the equipment delivered by it will be of the kind and quality described in the order and will be free of defects in **workmanship, material or factory preparation** when operated under normal use and services.

A. What's Covered at No Cost to You

The Basic Warranty covers the cost of all parts needed to repair any defective item on your Air-O-Lator product – that is, **defective in material, workmanship, or factory preparation**. Warranty repairs or adjustments – including all parts and labor connected with them – will be made at Air-O-Lator Corporation or an AUTHORIZED repair facility.

B. Products Covered

All aerators, fountains and de-icers using Franklin Electric 4" and 6" motors.

C. When It Begins

The Basic Warranty begins on either of the following dates, whichever is earlier:

- The date you take delivery of the Air-O-Lator product or
- The date when the product was first put into service – up to 18 months from the date of manufacture.

D. When It Ends

The Basic Warranty lasts for 36 months for the Font'n-Aire and Aquarian Commercial (12 months for equipment used in wastewater). Aquarian Aquaculture and the Ice-Away de-icer equipment is warranted for 24 months (12 months for equipment used in wastewater). The Aquarian Aquaculture and Aquarian Quantum equipment is warranted for 12 months.

E. Exceptions

Exceptions to the 36 month warranty and 24 month warranty are: equipment used in severe environments, which are warranted for 12 months, i.e., wastewater applications or where high concentrations of corrosive or abrasive material are present.

F. Registration and Operation Requirements

The Basic Warranty covers your Air-O-Lator product only if:

- It was built for sale in the U.S.
- It's registered in the U.S.
- It's used in the U.S. and
- It's operated and maintained in the manner described in your Owner's Manual.

3. What's Not Covered

3.1 Modifications Not Covered

A. Some Modifications Don't Void this Warranty but Aren't Covered

Certain changes that you might make to your product do not, by themselves, void this warranty. Examples of some of these changes are:

- Installing non-Air-O-Lator supplied parts, components, or equipment (such as a non-Air-O-Lator supplied Franklin Electric motor, stainless steel fasteners, or fountain nozzles).

But this warranty does not cover any part that Air-O-Lator did not supply. Nor does this warranty cover the cost of any repairs or adjustments that might be caused or needed because of the installation or use of non-Air-O-Lator parts, components, equipment, or materials.

Examples of the types of alterations not covered are:

- Installing accessories – except for genuine Air-O-Lator accessories approved for installation – such as lighting, propeller guards, rock covers, or motors.
- Labor to install or remove any Air-O-Lator product.

B. Modifications That Will Void Your Warranty

Disconnecting, tampering with, or altering the electric control panels will void your warranty, unless you or your repairing technician follows Air-O-Lator's requirements for repairing or replacing the controls.

Removing and operating Air-O-Lator equipment without Air-O-Lator approved electrical controls will also void this warranty. Using any electric cable, connectors or splices not provided or authorized by Air-O-Lator will also void this warranty.

3.2 Environmental Factors Not Covered

This warranty does not cover damage caused by environmental factors such as, chemicals, and salt. Nor does your warranty cover damage caused by **windstorms, hailstorms, tornadoes, lightning, power surges, brownouts, floods, earthquakes debris and animals.**

3.3 Maintenance Costs Not Covered

This warranty does not cover the cost of repairing damage caused by poor or improper maintenance.

This warranty does not cover the costs of your equipment's normal or scheduled maintenance I.e. annual propeller/impeller replacement, cleaning etc.

3.4 **Incidental and Consequential Damages Not Covered**

This warranty does not cover any incidental or consequential damages connected with Air-O-Lator products' failure, either while under warranty or afterward. Examples of such damages include:

- Lost time, Inconvenience; The loss of the use of equipment; The loss of personal or commercial property; The loss of revenue; and Delay

3.5 **Certain Kinds of Corrosion Not Covered**

This warranty does not cover the following:

- Corrosion caused by accident, damage, abuse, or alteration;
- Surface corrosion caused by such things as, sand, salt, stones and barnacles.
- Corrosion caused by the extensive or abnormal exposure of caustic materials like chemicals, acids, and fertilizers.

3.6 **Freight:**

Warranty shipping charges are to be pre-paid by the owner.
Warranty shipping charges are the responsibility of the owner.

4. How To Get Warranty Service

4.1 **Where to Take Your Air-O-Lator Product**

Air-O-Lator authorizes you to return your Air-O-Lator products to the factory **upon notification**.
You may contact: Air-O-Lator Corporation: 8100-04 Paseo, Kansas City, MO 64131, 1-800-821-3177.
<http://airolator.com>

CUSTOMER REGISTRATION COPY

| | |
|-----------------------|---------------------------------------|
| Owner Name _____ | Model _____ |
| Date Purchased _____ | Serial No. _____ |
| Owner Address _____ | Dealer Name _____ |
| City _____ | Address _____ |
| State _____ Zip _____ | City _____ State _____ Zip Code _____ |

NOTE: This information should be retained for your file.

AIR-O-LATOR CORPORATION, 8100-04 PASEO, KANSAS CITY, MO 64131
1-800-821-3177 <http://airolator.com>



MAIL IN FORM

WARRANTY REGISTRATION

Font' N-Aire

Aquarian

Ice-Away

Ready _____

Aquaculture _____

Platinum _____

Commercial _____

Gulf Stream _____

Aquaculture _____

Quantum _____

Purchase Date Mo. _____ Day _____ Year _____

Model No. _____

Serial No. _____

Owner Name _____

Dealer Name _____

Owner Address _____

Dealer Address _____

City _____

City _____

State _____ ZIP Code _____

State _____ ZIP Code _____



AIR-O-LATOR CORPORATION

REPAIR RETURN FORM

To avoid delays in the repair of equipment in question, it is best to call the factory at 1-800-821-3177 to determine what portion or portions of the equipment in question should be returned. The fountain or aerator unit itself (that portion that sets down into the hole in the floatation) is to be returned completely assembled. **DO NOT DISASSEMBLE ANY PORTION WITHOUT PRIOR AUTHORIZATION!**

Shipping costs to and from the factory are the responsibility of the shipper as is the packaging. Air-O-Lator encourages the use of the original shipping container that is UPS approved for this equipment to minimize the possibility of shipping damage. Additional charges will apply if original packaging is not retained.

If the original packaging is not retained and used by the customer, Air-O-Lator will supply replacement packaging (at a nominal charge) upon return of the equipment to the shipper (call for current pricing).

Upon the inspection of returned equipment, whether in warranty or not, contact by Air-O-Lator to proceed with repair will be made to the owner or agent with an explanation of the repairs and charges if any. **NO REPAIRS WILL BE MADE UNLESS AUTHORIZED BY THE OWNER OR AGENT.** If Air-O-Lator is unable to contact the owner/agent within 30 days after receipt of the equipment for repair, a “signature required” notice will be forwarded to the owner or agent stating that disposal of the equipment will be made 30 days from the date of the notice.

Name _____

Address _____

Phone _____ FAX _____ E-Mail _____

E-mail _____ Equipment Serial # _____

Comments: _____



THE WATER'S EDGE™

AQUARIAN PARTS LIST (AQUACULTURE)

| FOR 1HP ONLY | |
|----------------------------------|-------------|
| PART DESCRIPTION | PART NUMBER |
| CONTROL BOX 1.0 H.P., 230V., 1PH | 90CBA12301G |

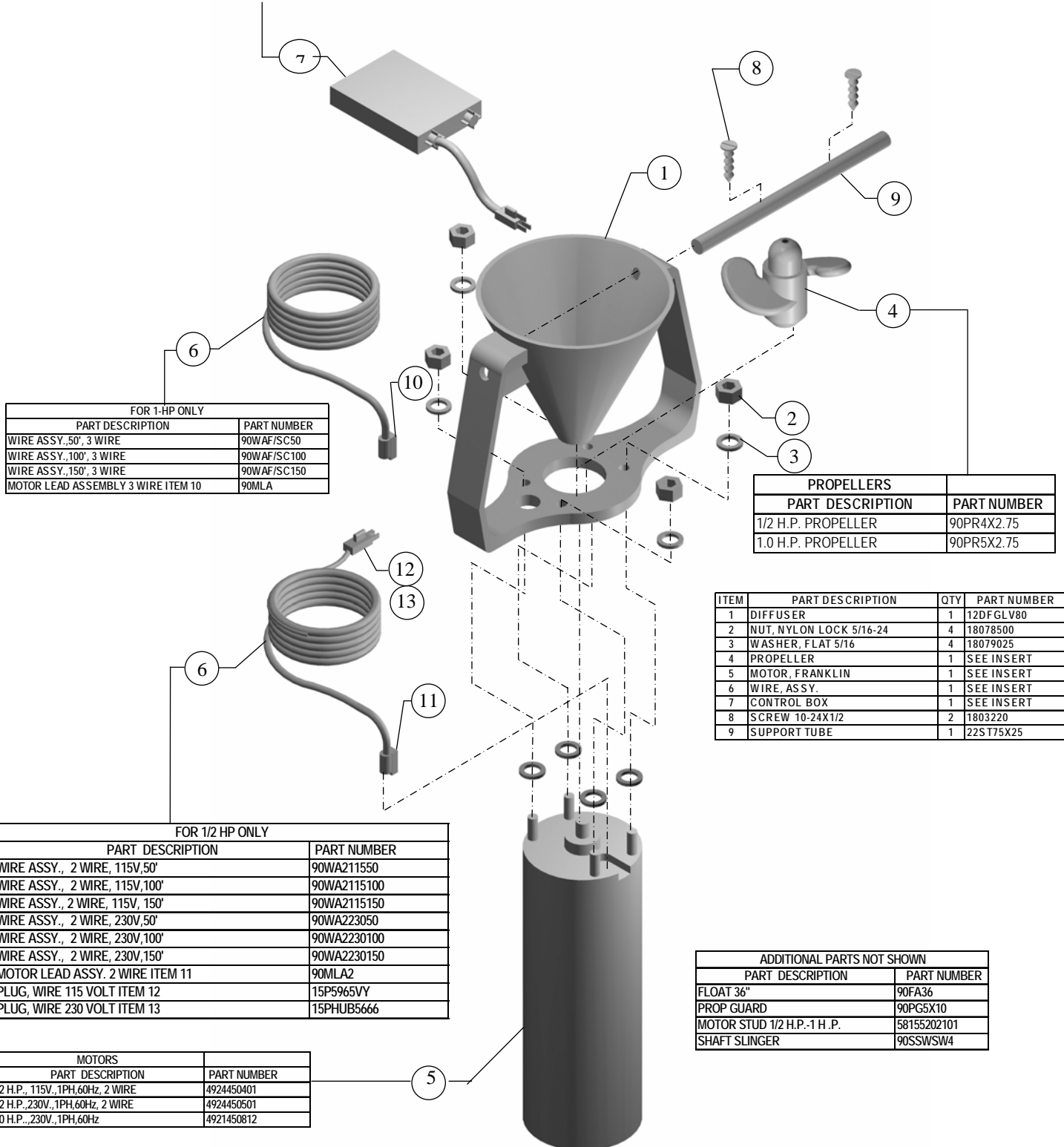

| FOR 1-HP ONLY | |
|------------------------------------|-------------|
| PART DESCRIPTION | PART NUMBER |
| WIRE ASSY., 50', 3 WIRE | 90WAF/SC50 |
| WIRE ASSY., 100', 3 WIRE | 90WAF/SC100 |
| WIRE ASSY., 150', 3 WIRE | 90WAF/SC150 |
| MOTOR LEAD ASSEMBLY 3 WIRE ITEM 10 | 90MLA |

| PROPELLERS | |
|--------------------|-------------|
| PART DESCRIPTION | PART NUMBER |
| 1/2 H.P. PROPELLER | 90PR4X2.75 |
| 1.0 H.P. PROPELLER | 90PR5X2.75 |

| ITEM | PART DESCRIPTION | QTY | PART NUMBER |
|------|-------------------------|-----|-------------|
| 1 | DIFFUSER | 1 | 12DFGLV80 |
| 2 | NUT, NYLON LOCK 5/16-24 | 4 | 18078500 |
| 3 | WASHER, FLAT 5/16 | 4 | 18079025 |
| 4 | PROPELLER | 1 | SEE INSERT |
| 5 | MOTOR, FRANKLIN | 1 | SEE INSERT |
| 6 | WIRE, ASSY. | 1 | SEE INSERT |
| 7 | CONTROL BOX | 1 | SEE INSERT |
| 8 | SCREW 10-24X1/2 | 2 | 1803220 |
| 9 | SUPPORT TUBE | 1 | 22S T75X25 |

| FOR 1/2 HP ONLY | |
|---------------------------------|-------------|
| PART DESCRIPTION | PART NUMBER |
| WIRE ASSY., 2 WIRE, 115V, 50' | 90WA211550 |
| WIRE ASSY., 2 WIRE, 115V, 100' | 90WA2115100 |
| WIRE ASSY., 2 WIRE, 115V, 150' | 90WA2115150 |
| WIRE ASSY., 2 WIRE, 230V, 50' | 90WA223050 |
| WIRE ASSY., 2 WIRE, 230V, 100' | 90WA2230100 |
| WIRE ASSY., 2 WIRE, 230V, 150' | 90WA2230150 |
| MOTOR LEAD ASSY. 2 WIRE ITEM 11 | 90MLA2 |
| PLUG, WIRE 115 VOLT ITEM 12 | 15P5965VY |
| PLUG, WIRE 230 VOLT ITEM 13 | 15PHUB5666 |

| ADDITIONAL PARTS NOT SHOWN | |
|----------------------------|-------------|
| PART DESCRIPTION | PART NUMBER |
| FLOAT 36" | 90FA36 |
| PROP GUARD | 90PG5X10 |
| MOTOR STUD 1/2 H.P.-1 H.P. | 58155202101 |
| SHAFT SLINGER | 90SSWSW4 |

| MOTORS | |
|------------------------------------|-------------|
| PART DESCRIPTION | PART NUMBER |
| 1/2 H.P., 115V., 1PH, 60Hz, 2 WIRE | 4924450401 |
| 1/2 H.P., 230V., 1PH, 60Hz, 2 WIRE | 4924450501 |
| 1.0 H.P., 230V., 1PH, 60Hz | 4921450812 |