



'THE WATER'S EDGE'

2008

AERATOR and FOUNTAIN

APPLICATION and INSTALLATION

INTRODUCTION

Air-O-Lator Corporation aerators and fountains are designed and manufactured to provide reliable, efficient and trouble free operation. There are four very simple requirements to enable a long operational life.

Those needs are:

1. Proper equipment for the application
2. Sufficient power supply to the equipment
3. Proper installation
4. Maintenance

All of the considerations of application, layout design, power supply requirements, installation and service relate to these three needs. The purpose of this manual is to acquaint you with these needs, to insure that these needs are being met, and to assist and direct you with service and maintenance when necessary.

CONTENTS

1. APPLICATION	Pages 3-6
2. LAYOUT DESIGN	Pages 7-10
3. LAYOUT DIAGRAMS	Pages 11-13
4. INSTALLATION	Pages 14-16
5. START UP	Pages 17-18
6. SERVICE/MAINTENANCE	Page 19
7. LIGHTING (for fountains only)	Page 19

ATTENTION!

FAILURE TO INSTALL THIS EQUIPMENT IN COMPLIANCE WITH NATIONAL AND LOCAL ELECTRICAL CODES, MAY RESULT IN ELECTRICAL SHOCK OR FIRE HAZARD, UNSATISFACTORY PERFORMANCE, AND EQUIPMENT FAILURE.

! WARNING:

SERIOUS OR FATAL ELECTRICAL SHOCK MAY RESULT FROM FAILURE TO CONNECT THE MOTOR, CONTROLS AND ALL OTHER METAL NEAR THE MOTOR OR CABLE, TO THE POWER SUPPLY GROUND TERMINAL USING WIRE NO SMALLER THAN THE MOTOR CABLE WIRES. TO REDUCE RISK OF ELECTRICAL SHOCK, DISCONNECT POWER BEFORE WORKING ON OR AROUND THE WATER. DO NOT USE THIS EQUIPMENT IN SWIMMING AREAS.

APPLICATION

In this section you will be learning how to select the proper type of equipment and the number of units required for the application. There are four (4) basic questions that must be answered to select the proper equipment.

1. What is the primary purpose of the equipment?
2. What is the purpose of the pond?
3. What is the water source?
4. What are the physical dimensions, (length, width and depth) and the shape of the pond?

1. EQUIPMENT PURPOSE:

There are three (3) basic reasons for installing a fountain or aerator in a body of water.

- A. Aeration to improve the quality of the pond.
- B. Aesthetic display.
- C. A combination of both aeration and aesthetics.

A. AERATION:

When the single function of the equipment is to aerate, the AQUARIAN aerator would be the appropriate equipment selection.

B. AESTHETICS:

When the single function of the equipment is for aesthetics, any of the fountain products (READY, PLATINUM or GULF STREAM) would be an appropriate selection based on what the customer finds appealing and fits the application.

C. AERATION and AESTHETICS:

When the primary purpose is aeration but the customer would also like a fountain display, the primary selection would be the CARNIVAL aerating fountain. Another option would be a combination of AQUARIAN aerators and display fountains or a combination of the Carnival aerating fountains and display fountains. Remember you must first take care of the primary purpose, which is aeration.

2. POND PURPOSE

A pond or body of water is built for many purposes, **recreation, retention, irrigation, aesthetics** or a combination of these. Each type of pond has particular characteristics that must be considered when selecting the type of equipment.

RECREATION:

Generally ponds and lakes that are used for recreation have a need for aeration to improve the overall quality of the water. The AQUARIAN aerator or the CARNIVAL fountain would be the appropriate selection. **Air-O-Lator aerators and fountains have not been certified for use in swimming areas. Therefore Air-O-Lator does not recommend or knowingly sell any type of Air-O-Lator product for use in swimming areas.**

Air-O-Lator suggests in areas where fishing and boating is permitted, you should be aware of potential concerns and to take them into consideration. Fishing line, lures and hooks can snag onto the equipment or the power cord therefore causing mechanical or electrical problems. In areas where boating is permitted this can present hazards to the equipment and boaters. These potential hazards should be discussed with the customer and steps taken to eliminate or at least insure the customer is aware of these concerns.

RETENTION:

This type of impoundment is probably the most common type. Due to government regulations and requirements to retain water runoff, retention ponds are found everywhere. Retention ponds will require aeration making the AQUARIAN aerator or the CARNIVAL aerating fountain the equipment of choice. However, because these impoundments are built around homes, businesses, and high profile areas, many installations will want more of an aesthetic display. It would be prudent to suggest a combination of equipment. Retention ponds are also one of the most demanding applications. Typical characteristics of retention impoundments include; flooding due to heavy rains which will wash in debris, low water conditions during droughts, silt build up, trash thrown in the pond or blown in from the surrounding area.

IRRIGATION:

Ponds or lakes that are used for irrigation will require aeration to reduce algae build up, which can clog the irrigation system and damage the irrigation pumps. Most of the irrigation impoundments will have some type of water level control. The AQUARIAN aerator or the CARNIVAL aerating fountain would be the proper choice of equipment.

AESTHETICS:

Ponds, water gardens or pools which are built for beautification and landscaping which do not need or require aeration for water quality are open to any of the fountain spray patterns that the customer finds appealing and fits the application. The READY, PLATINUM, or GULF STREAM would be the equipment of choice.

3. WATER SOURCE:

The type of water source will provide certain characteristics inherent to the pond. There are four (4) basic water sources, **runoff, river/stream, well water** and **reclaimed effluent**.

1) RUNOFF:

Ponds or bodies of water that are fed by runoff from rain will generally have silt build up, heavy concentrations of fertilizer, and vegetation. Aeration will be required for this type of application and the AQUARIAN aerator or the CARNIVAL aerating fountain would be the best choice.

2) RIVER/STREAM:

Ponds or impoundments created by rivers or streams during normal conditions will generally have good flow through them and the aeration requirement is not as great. However during drought or low flow conditions the aeration demand will increase. The AQUARIAN aerator or CARNIVAL aerating fountain would be the best choice for this application.

3) WELL WATER:

The water from underground wells or springs is void of oxygen and should be treated by the AQUARIAN aerator or CARNIVAL aerating fountain.

4) RECLAIMED EFFLUENT:

Ponds fed by reclaimed effluent from wastewater plants will generally have high concentrations of nitrates and will require aeration to prevent algae growth. The AQUARIAN aerator or the CARNIVAL aerating fountain would be the best choices for this application.

With the exception of aesthetic pools most bodies of water will require some degree of aeration requirement. Too many times this factor is over looked, and the wrong type of equipment is installed. With the modular design of AIR-O-LATOR equipment, many customers will purchase a second unit of the same horsepower, voltage and phase, less the float, wire and controls and simply switch units out to meet their needs.

4. PHYSICAL DIMENSIONS OF THE POND

The physical dimensions and shape of the pond is needed in determining the horsepower and number of units for the application. The surface area (length X width) is essential to determine the total horsepower for aeration. The depth is essential to insure that the required minimum operating depth of the equipment is met. The shape of the pond or impoundment is important in determining the number of units.

When aesthetics are the requisite, the horsepower of the fountain will determine the height and diameter of the desired spray pattern. The size and shape of the pond must be larger than the spray diameter of the nozzle chosen. Also the spray height must be considered as well. Prevailing winds or high winds will cause water to over spray outside the impoundment.

When aeration is the primary concern, the physical dimension and shape of the impoundment will directly relate to the horsepower and number of units needed. A basic "rule of thumb" is to supply 800 to 1,000 gpm of water to be pumped into the atmosphere per minute per surface acre.

It is important to point out that attempting to aerate 100% of an impoundment's gallonage is not practical or necessary and would be a waste of electrical energy and equipment capital.

Examples of aerator sizing:

- a) For a 1/10th acre up to a 1/2 acre lake 350 to 500 gpm pumping rate is acceptable.
- b) Based on a 3/4 acre to 1-1/2 acre lake 800 to 1400 gpm is an acceptable pumping rate. For acreage's between 1/2 acre and 3/4 acre, use the higher horsepower if water depth will allow you to.
- c) A three- (3) acre lake would require a minimum of 2,400-gpm pumpage.
- d) It is important to realize that one large unit such as a three horsepower aerating unit in a (3) acre lake will not disperse oxygen as thoroughly throughout a lake as would multiple units of a lower horsepower to permit a larger area of dispersed oxygenated water throughout the impoundment.
- e) The shape of the pond and obstructions in a pond will also dictate the number of units needed. i.e. square, rectangular or with islands or angle bends
- f) The depth of the pond will also be a determining factor of the horsepower that can be used. The minimum depth requirements are as follows; 1/2 horsepower is 18", 1 and 2 horsepower is 24", 3 horsepower is 34" and the 5 horsepower is 48".

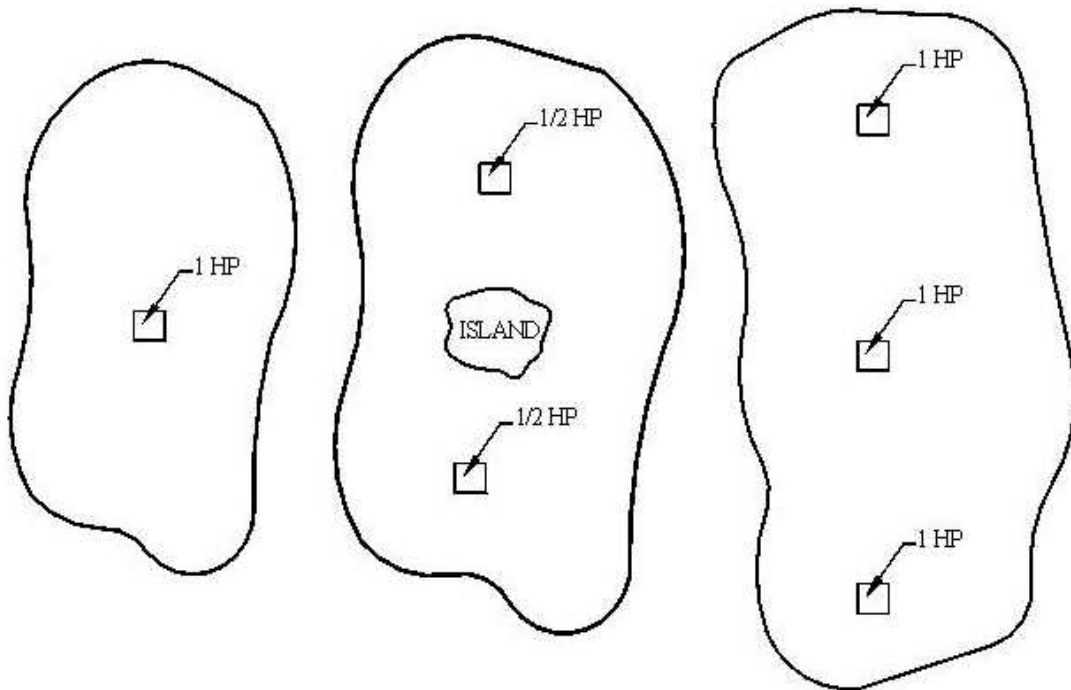

1 Acre Pond =
1-1hp Unit

1 Acre Pond =
2-1/2hp Units

3 Acre Pond =
3-1hp Units

This concludes the first step in selecting what type and number of units that would be best suited for a body of water's needs.

LAYOUT DESIGN

The selection of the proper type and number of units is critical to insure proper results and satisfaction. Just as important is the layout design to insure proper operation, longevity and ease of service. There are several factors that must be known to determine the best layout design for every application. These factors are:

1. Available power supply (voltage and phase)
2. Service entrance location
3. Control panel location
4. Equipment location
5. Equipment power cable selection

1. AVAILABLE POWER SUPPLY (voltage and phase)

The first step in determining a layout design is to determine what electric voltage and phase is available. Typical voltages available in the U.S. are 115 volts, 208/ 230volts single phase, 208/ 230volt and 460-volt three-phase. When the available power supply voltage is not within the proper range for a motor, a buck-boost transformer of the appropriate KVA is to be used to adjust the voltage to match the motor. For example to boost 208volts to 230volts a .75 KVA boost transformer would be installed prior to the fountain controls to correct the voltage.

Although Franklin Electric allows 230volt single-phase motors to operate on 208volts 1 phase, Air-O-Lator strongly suggests that 230volt single-phase service be the standard choice of supply voltage since there is not much voltage error allowance (a maximum of $\pm 10\%$ of the rated motor voltage is permitted) at 208volts. Additionally, if lighting is purchased, the transformer Air-O-Lator uses is rated 115/240volt. Any decrease in supply voltage will diminish the 12volt 50watt light output.

All Air-O-Lator single-phase equipment is supplied with GFCI protection. The use of three-phase power is only an advantage when extremely long power cable lengths are needed. Three-phase GFCI are available but are not standard.

FOUNTAIN INSTALLATIONS: The National Electric Code (NEC) article 680, under fountains section V. 680.51 (B) states that, "Submersible pumps and other submersible equipment shall operate at 300 volts or less between conductors".

Therefore Air-O-Lator disagrees with manufacturers that permit higher voltages in fountain applications. **Air-O-Lator Corporation does not manufacture FOUNTAIN equipment that operates on voltages greater than 300-volts.**

Aerators are apparently exempt from this code restriction and are available in 480volts, three phase.

2. SERVICE ENTRANCE LOCATION

The location of the service entrance (main circuit panel) is important in determining the proper size (gauge) wire to provide to the controls/splice box for the aerator/fountain located at the waters edge.

First measure the distance from the service entrance to the waters edge (location of controls/splice box for the aerator/fountain).

Second measure the distance from the control/splice box at the waters edge to the location where the aerator/fountain will be installed. **(DON'T FORGET TO INCLUDE THE DEPTH OF THE POND x 2 TO YOUR DISTANCE)**

Add these two distances together, this will provide you with your overall distance from the main service entrance to the aerator/fountain.

Based on the overall distance, horsepower, voltage and phase use the appropriate chart below to determine the proper gauge wire to install from the main service entrance (main circuit panel) to the controls/splice box at the waters edge.

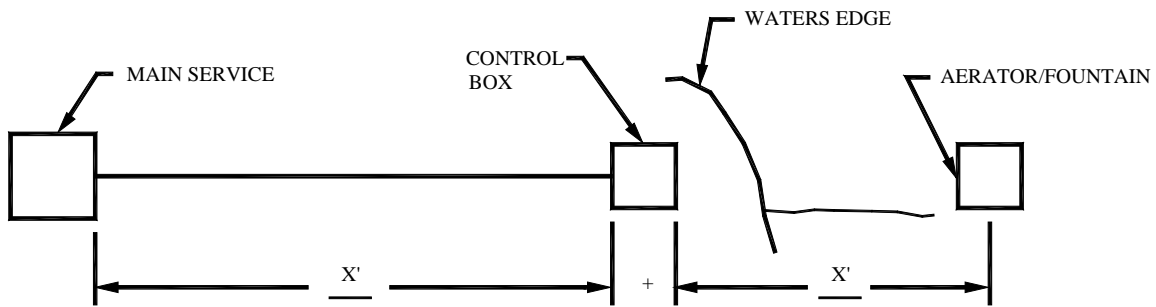

Service Entrance to Aerator/Fountain, Minimum Gauge Size, Cable Selection
Single Phase, 60 HZ – Maximum Length in Feet

MOTOR RATING VOLTS	HP	AWG COPPER WIRE SIZE					
		14	12	10	8	6	4
115	0.5	NA	150	250	400	600	1000
230	0.5	NA	650	1000	1600	2500	4000
230	1	NA	400	600	1000	1500	2400
230	2	NA	250	400	600	1000	1500
230	3	NA	200	300	450	750	1200
230	5	NA	0	200	250	450	700

Service Entrance to Aerator/Fountain, Minimum Gauge Size, Cable Selection Guide
Three Phase, 60 HZ – Maximum Length in Feet

MOTOR RATING VOLTS	HP	AWG COPPER WIRE SIZE					
		14	12	10	8	6	4
230	1.5	NA	650	1000	1600	2600	4000
460	1.5	NA	2700	4200	6500		
230	2	NA	500	800	1200	2000	3000
460	2	NA	2000	3200	5100	8000	
230	3	NA	400	600	1000	1500	2400
460	3	NA	1600	2500	4000	6200	
230	5	NA	200	350	600	900	1400

In applications where it is not possible to install the equipment controls at the waters edge, it is strongly suggested that a shore mounted junction box be installed at the waters edge to provide a water tight connection between the aerator /fountain and the supply power cable. Determining the proper gauge wire from the controls to the shore mounted box is the same as shown on the previous page.

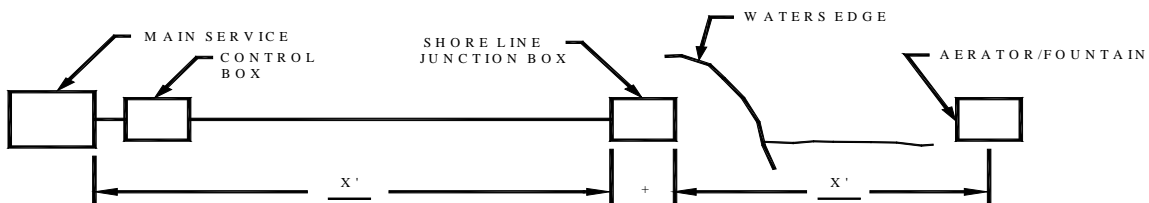

NOTE: Single phase control panels are of a three wire design. No neutral is used. On 1, 1 1/2, 2, 3 and 5 horsepower single and three-phase equipment requires four (4) wires from the control panel to the splice junction box. The wires should be color-coded as follows, **green, yellow, black and red** to permit easy tracing of the circuit if ever required.

3. CONTROL PANEL LOCATION

The ideal location for the control panel is as near the waters edge as possible and out of direct sunlight or high temperature locations to minimize the negative influence on the electrical components. These precautions will reduce the possibility of nuisance tripping and control panel component failures.

Note: In the instance of **single phase** Aquarian and Font' N-Aire equipment the wire color code is as follows: Black, White or Yellow, wires are connected to the Run windings of the motor. The Red wire is connected to the Start winding. The green is ground.

4. EQUIPMENT LOCATION

Selection for the location of the aerator or fountain has already been determined. However you should:

1. Insure that the location has the proper depth of water for the size horsepower selected.
2. Insure that the spray pattern diameter will not exceed the boundaries of the pond.
3. Prevailing winds should be considered, to minimize water spray drifting outside the pond.
4. Locate an aerating device in the center of the largest open area for maximum dispersion of oxygen throughout the aerator's zone of influence.
5. Do not place the unit near the influent or effluent of a pond.

5. EQUIPMENT POWER CABLE SELECTION *(Service Entrance to Motor)*

Selecting the proper gauge of wire is critical to insure proper operation of the equipment. Voltage drop can occur when to small of a gauge of power cable is selected for the unit chosen. This can cause improper operation of the equipment and premature failure of the motor. While the equipment is running the voltage must be $\pm 10\%$ of the rated name plate voltage of the motor. See the cable selection guide page 6.

6. USING TWO DIFFERENT CABLE SIZES *(The use of smaller than suggested cable will void motor warranty).*

The example below is for reference based on **3hp 230 volt single phase supply voltage.**

Depending on the installation, any number or combinations may be used, as long as the total percentage length of the cables does not exceed 100% of the total allowable length. If this rule is followed adequate voltage will be supplied to the motor.

In the replacement equipment situation shown below 300ft of #6 buried cable is located between the service entrance and the waters edge. The question is: What size aerator/fountain cable should be selected?

1. According to the single-phase table on page 6, six (6) gauge cable is large enough for the total run of a 3hp aerator/fountain. The percent of the maximum allowable cable used by a 310' length of cable is 41%. ($310' \div 750 = 41\%$).
2. Since 41% of the total run (service to aerator/fountain) is used by the existing #6 cable (service to the waters edge) there is 59% left for the aerator/fountain cable selection (waters edge to the aerator/fountain).
3. If one calculates 59% of 200' of #12 wire per the cable selection chart on page 6 ($200' \times .59 = 118'$) there would be a sum of 118' of #12 wire that could be used. 150' is required and 118' is available.

The next step is to try #10 gauge wire. ($300' \times .59 = 177'$). 177' is more than enough to satisfy the requirement of 150'.

You have now selected the type and number of units needed.

You have selected the layout design.

You have determined the electrical power available

You have selected the appropriate wire size needed.

RECOMMENDED LAYOUT INSTALLATION-SINGLE UNITS

OPTION 1

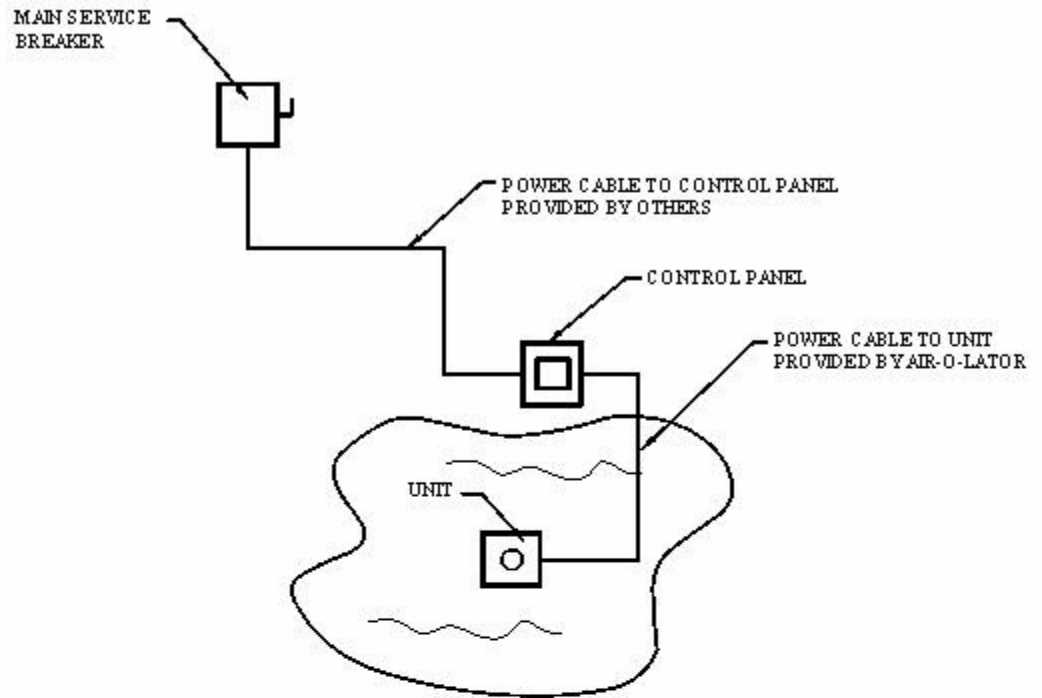

OPTION 2

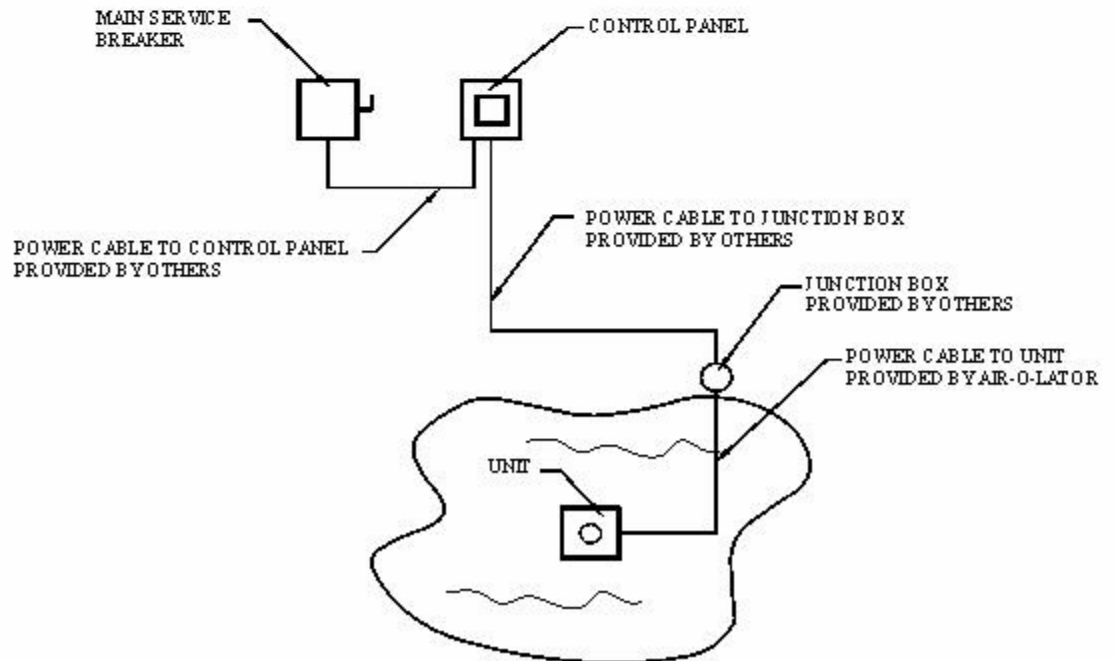

RECOMMENDED LAYOUT INSTALLATION-MULTIPLE UNITS

OPTION 1

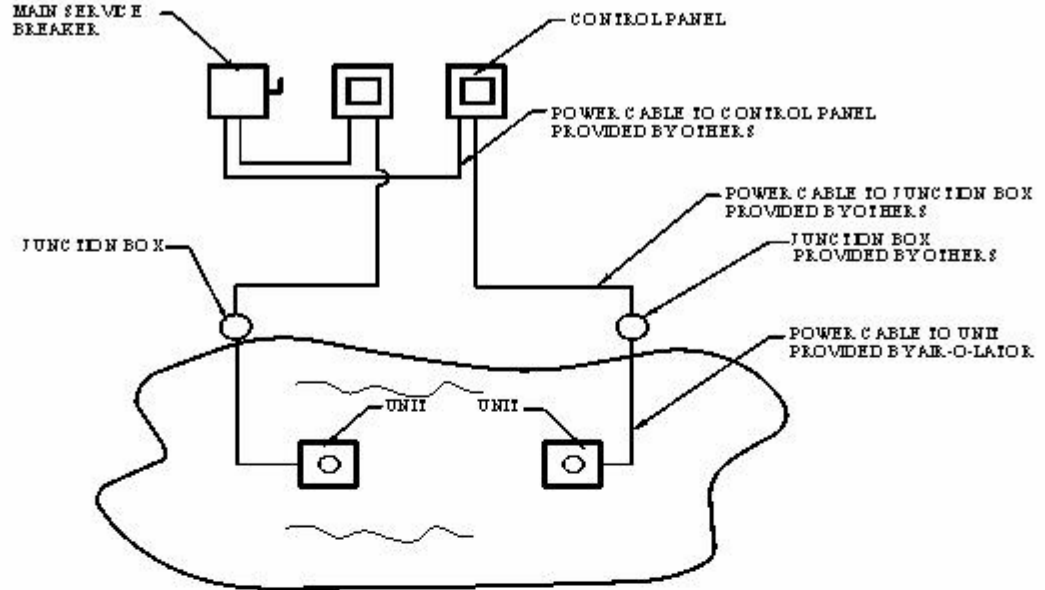

OPTION 2

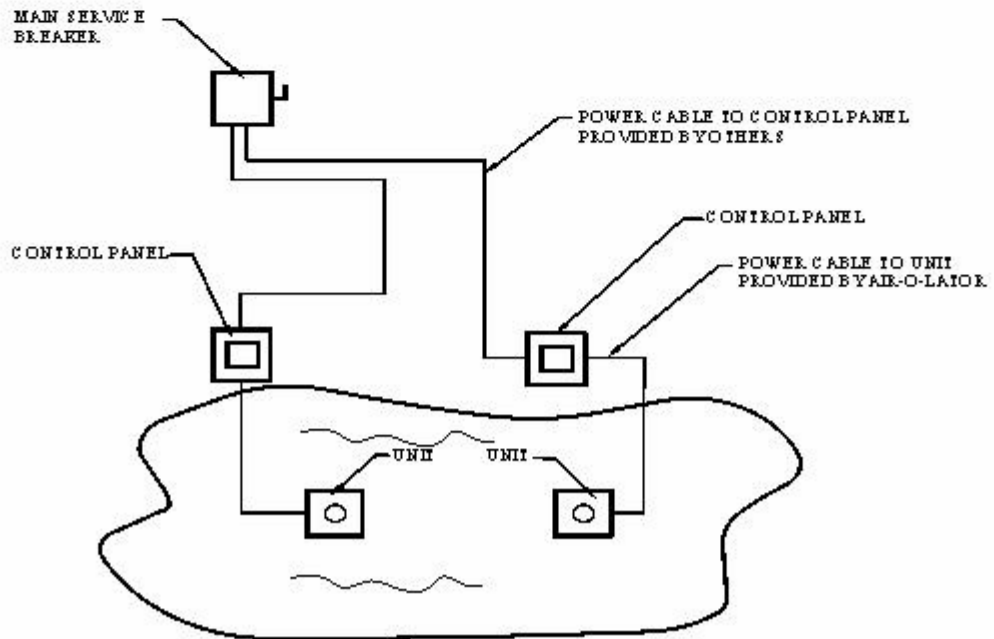

RECOMMENDED LAYOUT INSTALLATION OF DOG LEG, HOUR GLASS AND ISLAND TYPE PONDS

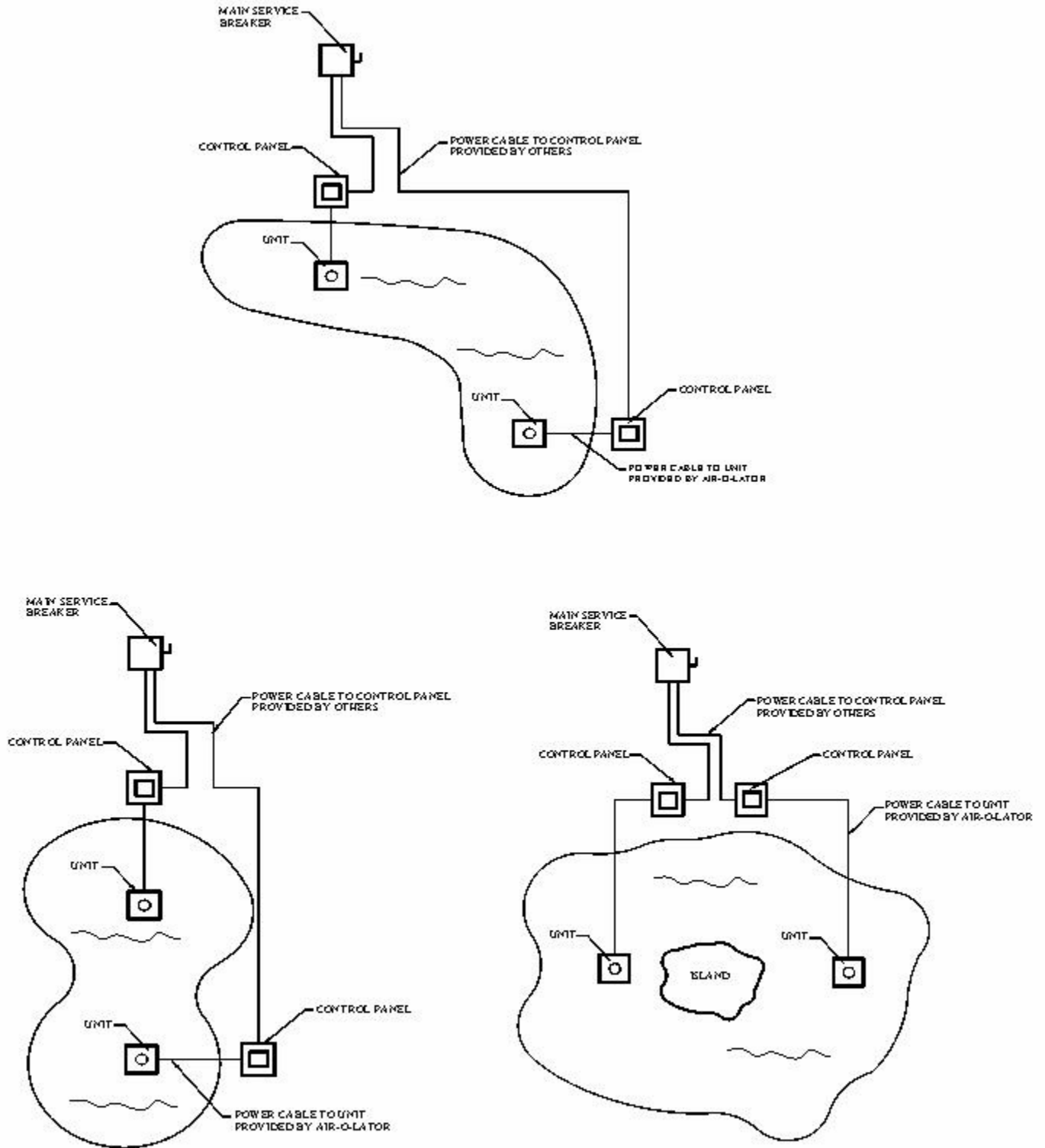

INSTALLATION

Air-O-Lator has designed its equipment so that the installation is quick and easy. There are four (4) major components to the aerators and fountains we manufacture.

1. Control Panel
2. Power cable
3. Flotation
4. Unit (aerator/fountain)

CONTROL PANEL

No matter what type of equipment is purchased every unit will be supplied with some type of operating controls. These controls should be located near the water's edge and located along the pond so that the power cable to the unit can be as direct of a run as possible.

POWER CABLE

The power cable provided with the equipment is sized per the NEC and is UL listed and rated for wet locations. Each power cord assembly is provided with a UL recognized watertight connector. A watertight "Female" power cable connector attaches to a strain relief non-watertight box that houses, for ease of service, a UL recognized for submergence "KING®" splice connection.

FLOTATION

Each unit is provided with a flotation device. The Air-O-Lator floats are constructed out of heavy wall polyethylene plastic and filled with closed cell, non-hygrosopic pressure molded polystyrene. The floats are square to provide stability and only 4" thick.

UNIT (AERATOR/FOUNTAIN)

Each unit is shipped completely assembled and ready for installation and has been operated in water to verify correct operation and performance at the rated voltage. Each unit has a watertight "Male" connector mounted in a non-watertight strain relief box that houses for ease of service a UL recognized for submergence "KING®" splice connection.

INSTALLATION PROCEDURES

ALL ELECTRICAL CONNECTIONS SHALL BE WIRED PER N.E.C., C.E.C., OR LOCAL ELECTRICAL CODES

1. CONTROL PANEL INSTALLATION

The control panel should be located near the waters edge and located along the pond so that the power cable (Air-O-Lator supplied) to the unit can be as direct of a run as is possible. Typically the control panel is mounted to a suitable mounting structure, located along the waters edge. Insure the control panel is far back enough and elevated enough for high water conditions and ease of service. It is recommended that a conduit be run from the control panel into the water a short distance to protect the power cable to the unit from vandals, lawn mowers, weed eaters etc and will also hide the power cable from view.

Do not mount the control panel in direct sunlight or high temperature locations. As was mentioned previously this can cause shortened component life and unnecessary nuisance tripping. Another undesirable place to mount the control panel is in an unventilated damp well pit or other extremely humid location. Control panels should be mounted in an upright and vertical position. Mounting them in other configurations will affect the operation. In some situations the control panel is required to be located in a remote location such as a pump house or garage. Mount the control panel in the remote location desired vertically. Provide a conduit or direct burial cable and run it under ground between the remotely mounted control panel and a junction box. The junction box is usually placed at ground level at the water's edge. The Air-O-Lator supplied unit power cable is to enter the unit side of the junction box using an appropriate strain relief device. It is mandatory that the splice made between the conduit or cable connected power supply to the unit cable is watertight. "KING®" splice connections work well.

2. FLOAT INSTALLATION

Position the float in the impoundment where the unit is desired. (Face the Air-O-Lator logo up) To anchor the float in position cut two lengths of 1/4 " polyethylene rope, allowing approximately 2 to 3 feet of rope to 1 foot of water depth. Insert one end of each rope into the float through the molded and tapered holes provided in each corner of the float. Only two anchoring ropes are needed and should be positioned at opposing diagonal corners of the float. Tie a knot in each rope large enough to withstand being pulled all the way through the float and pull into each tapered hole.

On the other end of the rope secure a standard 8"x 8"x16" concrete building block. Submerge the concrete building blocks out and away from the float allowing a little slack in the rope for water fluctuation and wind.

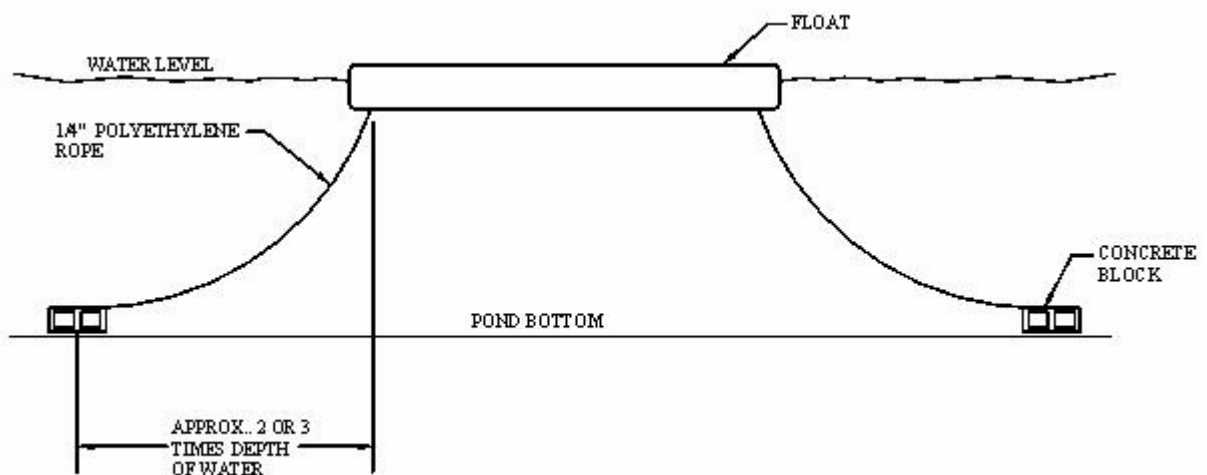

3. UNIT INSTALLATION

Place the unit into the center of the float with motor end first and the mounting supports positioned into the square molded areas in the float. No mounting hardware or tools are needed.

Note: On three-phase equipment check rotation of the motor before installing the unit in the water. (See page 15)

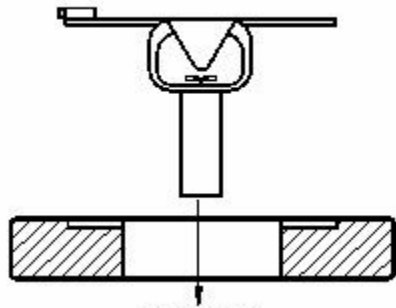

AQUARIAN
AERATOR

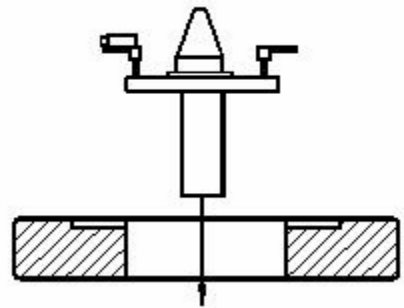

READY & PLATINUM
FOUNTAIN

4. POWER CABLE INSTALLATION

1. Connect the power cable to the unit. Insert the male connector of the power cord into the female connector on the unit and tighten the jam nut hand tight. (Do not over tighten as damage can occur)
2. Connect the other end of the power cable to the operating control panel. The unit is now ready for operation.

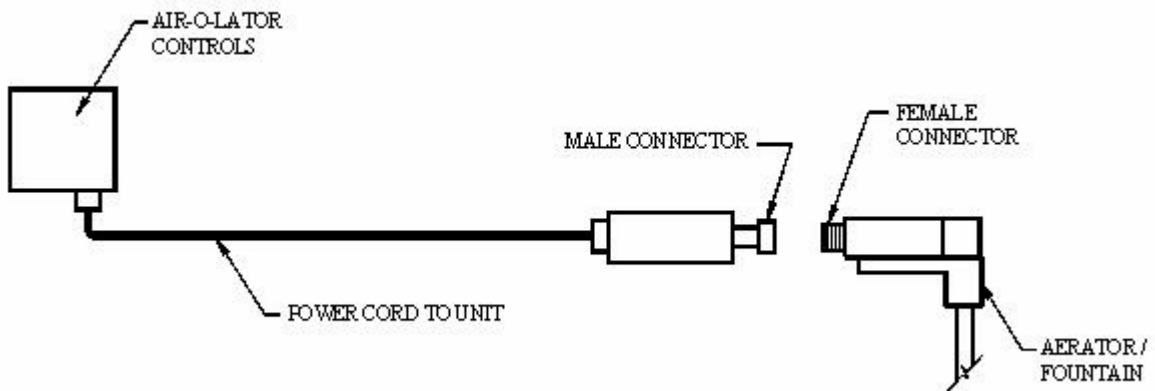

START UP

It is imperative that you check and record the amperage and voltage of the equipment during operation. Place this information within the control panel for future reference. IT IS NORMAL FOR ALL FRANKLIN MOTORS HAVE WATER INSIDE FOR COOLING AND LUBRICATION. **NEVER** TAKE A MOTOR APART.

SINGLE PHASE

Turn power on and engage starting switch to unit. With the unit operating check voltage and amperage. Verify that the unit is operating within the motor specifications of the horsepower installed.

Single Phase Motor Specifications (60 Hertz) 3450 RPM

TYPE	HP	VOLTS	MAX.LOAD AMPS	MAX. LOAD WATTS
2 wire MOTOR	0.5	115	12.0	970 @ 73% power factor
	0.5	230	6.0	970 @ 73% power factor
3 WIRE MOTOR	1	230	9.8	1600 @ 74% power factor
	2	230	13.2	2650 @ 69% power factor
	3	230	17.0	3650 @ 69% power factor
	5	230	27.5	5900 @ 74% power factor

THREE-PHASE

On three-phase equipment you must **check rotation** of the motor prior to installing the equipment in the water. To avoid possible motor/propeller damage correct motor rotation is **counter clockwise** when looking down on the motor shaft. To correct the rotation of the motor interchange any two leads of the incoming power.

Example:

L1 L2 L3 **EXCHANGE ANY TWO LEADS** L3 L2 L1

Remove L1 and put in place of L3. Place L3 onto L1

After proper **counter clockwise** rotation is determined install the unit into the float.

Turn the power on and engage starting switch. Verify that the unit is operating within the parameters of the selected motor horsepower and voltage.

Three Phase Motor Specifications (60 Hertz) 3450 RPM

TYPE	HP	VOLTS	MAX.LOAD AMPS	MAX.LOAD WATTS
4 inch MOTOR	2	230	8.1	2700 @ 69% Power Factor
	2	460	4.1	2700 @ 69% Power Factor
	3	230	10.9	3420 @ 75% Power Factor
	3	460	5.5	3420 @ 75% Power Factor
	5	230	17.8	5810 @ 74% Power Factor

Three Phase Current Unbalance

A true three-phase supply is recommended for all three-phase motors, consisting of three individual transformers or one three-phase transformer. Open delta or wye connections using only two transformers can be used, but are more likely to cause problems, such as poor performance, overload tripping or early motor failure due to current unbalance.

Checking and Correcting Current Unbalance

On three-phase equipment you must balance the current draw to insure an electrically balanced system. After correct rotation has been established, check the current in each of the three motor leads and calculate the current unbalance.

1. Add the three line amps values together
2. Divide the sum by three, yielding average current.
3. Pick the amp value, which is furthest from the average current (either high or low).
4. Determine the difference between this amp value and the average
5. Divide the difference by the average. Multiply the result by 100 to determine percent of unbalance.

Example:

$$\begin{array}{r} \text{T1-Y} = 15.0 \\ \text{T2-B} = 12.0 \\ + \text{T3-R} = 16.0 \\ \hline \text{Total} = 43.0 \\ \text{Div. by 3} = 14.33 \\ - 12.0 = 2.33 \text{ (12.0 was the furthest from the average)} \\ 2.33 \text{ Divided by } 14.33 = 0.16 \times 100 = 16.0 \text{ or } 16\% \end{array}$$

If current unbalance is more than 2%, current readings should be checked on each leg using each of the three possible hook-ups. **Roll** the motor leads in the same direction to prevent motor rotation reversal.

Example:

<u>1st hook-up</u>	<u>2nd hook-up</u>	<u>3rd hook-up</u>
T1-Yellow	T3-Red	T2-Black
T2-Black	T1-Yellow	T3-Red
T3-Red	T2-Black	T1-Yellow

Current unbalance should not exceed 5% at service factor load or 10% at rated input load. If the unbalance cannot be corrected by rolling the leads, the source of the unbalance must be located and corrected. If, on the three possible hook-ups, the leg farthest from the average stays on the same power lead, most of the unbalance is coming from the power source. However if the reading farthest from the average moves with the same motor lead, the primary source of unbalance is on the “motor side” of the starter. In this instance consider a damaged cable, leaking splice, poor connection, or faulty motor winding.

SERVICE / MAINTENANCE

Air-O-Lator aerators and fountains have been designed and built to be virtually maintenance free. However, Air-O-Lator does recommend that periodic inspection be performed to extend the longevity of the equipment.

1. Periodically remove the unit and remove any foreign material that may have entangled around the unit or propeller/impeller or upon the occasion when the unit appears to operate improperly.
2. Check the propeller for wear or damage. If worn even slightly or obviously damaged replace or service the propeller.
3. Periodically check the voltage and amperage and compare it to the voltage and amperage recorded at start up. If there is a difference in amperage of one (1) amp or more, investigate the reason and correct it.
4. Clean the unit. Build up of foreign deposits will decrease the longevity of the equipment and affect the operation and performance. Deposit build up on the motor will not allow the motor to properly cool which will effect the operation, performance and longevity of the motor.

Remember and emphasize to the customer that preventative maintenance is the key to extended operation and performance of the equipment.

LIGHTING

The lighting system manufactured by Air-O-Lator for the floating fountains consists of four (4) 50-watt sealed beams, 12 volt, photo cell-controlled, mounted in non-water tight sealed beam housings. The light kit is offered as an option, to be installed at the time of initial installation of the fountain or at a later date. The light kit is self-contained. You do not need to install additional timers, controls or power cable. The entire package is mounted to the float and is above the water. Neither the unit nor the float need be removed for installation of the lighting package.

Simply install the lights and power pack onto the float.
Attach the counter weight to offset the transformer weight.
Connect the same power cable that operates the unit into the power pack and the installation is complete.

12-volt Light Assembly



12-Volt Power Pack Assembly



